

Recycled paper to protect the environment!

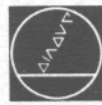

**HEIDENHAIN**

## **Technical Manual**

TNC 2500

# Contents

**Introduction** \_\_\_\_\_ **IN**

**Technical description** \_\_\_\_\_ **T**

**Machine parameters and commissioning** \_\_\_\_\_ **C**

**PLC-description** \_\_\_\_\_ **P**

# Introduction

This manual contains information on the installation, electrical connection, commissioning and PLC-programming of the HEIDENHAIN TNC 2500 contouring controls.

The contents of this manual are divided into various chapters:

- **Technical description:**  
Technical data, Hardware components, Connections and Dimensions, Grounding plan
- **Machine parameters and Commissioning:**  
Complete list of machine parameters with brief descriptions
- **PLC-description**  
Description of PLC-commands, markers and modes

An overview at the beginning of each chapter helps the user to easily find the desired section.

# Chapter overview

	Section	Page
Technical data	T1	1
Hardware components	T2	1
Connections	T3	1
Dimensions	T4	1
Grounding plan	T5	1

TNC 2500 is a contouring control for 4 axes which finds application not only on shop floor-programmable milling and boring machines, but also on production machines.

Operation and programming is performed in HEIDENHAIN-dialogue, i.e. plain language question and messages which prompt the operator step-by-step through the programming routine. The alpha-keyboard permits the entry of comments. Program entry is also possible in ISO (G-code)-format. TNC 2500 constitutes a fully fledged standard control.

Workpiece set-up is simplified via the touch probe functions in conjunction with the HEIDENHAIN touch probe systems TS 120 and TS 511. These touch probes perform electronic workpiece alignment and automatic datum setting.

Programmed probing with the touch probe is possible during the execution of a machining program e.g. for checking workpiece geometry. In the event of a deviation, the error can be compensated through a datum shift. With the data interface RS-232-C/V.24 the TNC-control is suited for external program transfer. Excessively long programs can be transmitted from an external data medium e.g. the HEIDENHAIN Floppy disc unit FE 401, to the TNC via "Transfer blockwise" and simultaneously executed.

<b>Components</b>	.Logic unit LE 2500 .TNC-keyboard unit TE 2500 .Graphics VDU (12 inch 512 x 256 Pixels)
<b>Control type</b>	.Contouring control for 4 axes .Linear interpolation in 2 out of 4 axes .Circular interpolation in 2 out of 4 axes
<b>Program memory</b>	.Buffered semi-conductor store 32 NC-programs 3100 program blocks .Connection of an external bulk memory possible via the RS-232-C/V.24 data interface
<b>Tool file</b>	.99 tools
<b>Operating modes</b>	.Manual .Electronic handwheel/Jog .Positioning with MDI .Program run single block .Program run full sequence .Transfer blockwise via data interface with simultaneous machining .Programming and editing .Program test (logical and graphic)
<b>Program input</b>	in HEIDENHAIN plain language dialogue or in ISO (G-code)-format .manually via TNC-keyboard or .externally via data interface
<b>Programmable functions</b>	.Nominal position (absolute or incremental) in Cartesian or polar coordinates .Linear path in 3 out of 4 axes .Circular path in 2 out of 4 axes .Helical path .Rounding of corners/Chamfer .Tangential approach to – and departure from – a contour .Tool number/Tool length and radius compensation .spindle speed .Rapid traverse .Feed rate .Recall of programs into other programs .Subprograms and Program part repeats .Canned cycles for Peck-drilling, Tapping, Slot milling, Rectangular pocket milling, Circular pocket milling .Datum shift, Coordinate system rotation, Mirror-image, Scaling .Dwell time/Auxiliary functions M/Program stop



TNC 2500 consists of the following components:

- **Logic unit LE 2500**

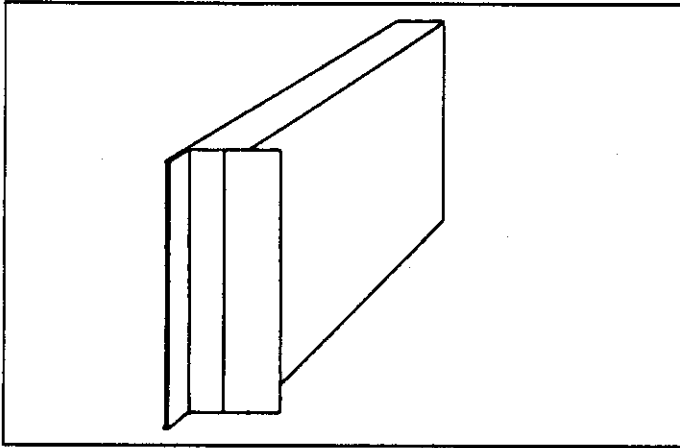

- **Visual display unit BE 212**  
connected to the logic unit via special cable

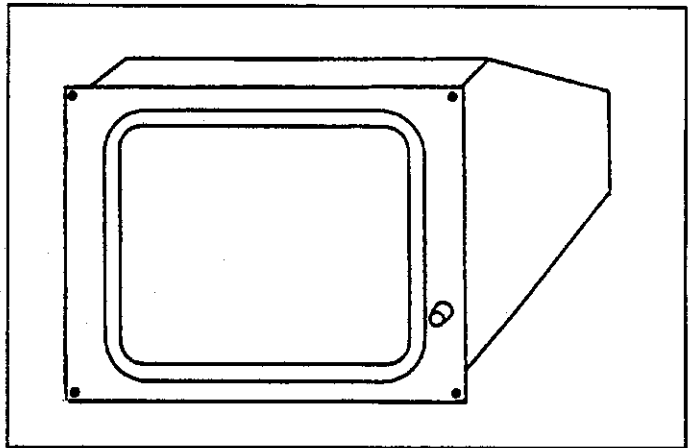

- **TNC Keyboard unit TE 2500**  
connected to the logic unit via special cable

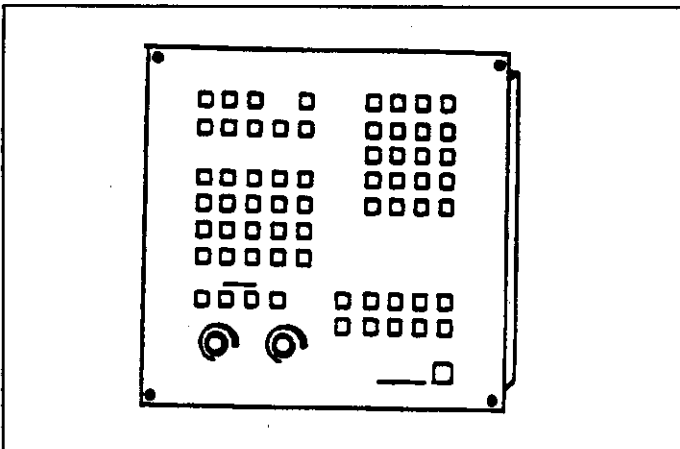

# Cable Diagram

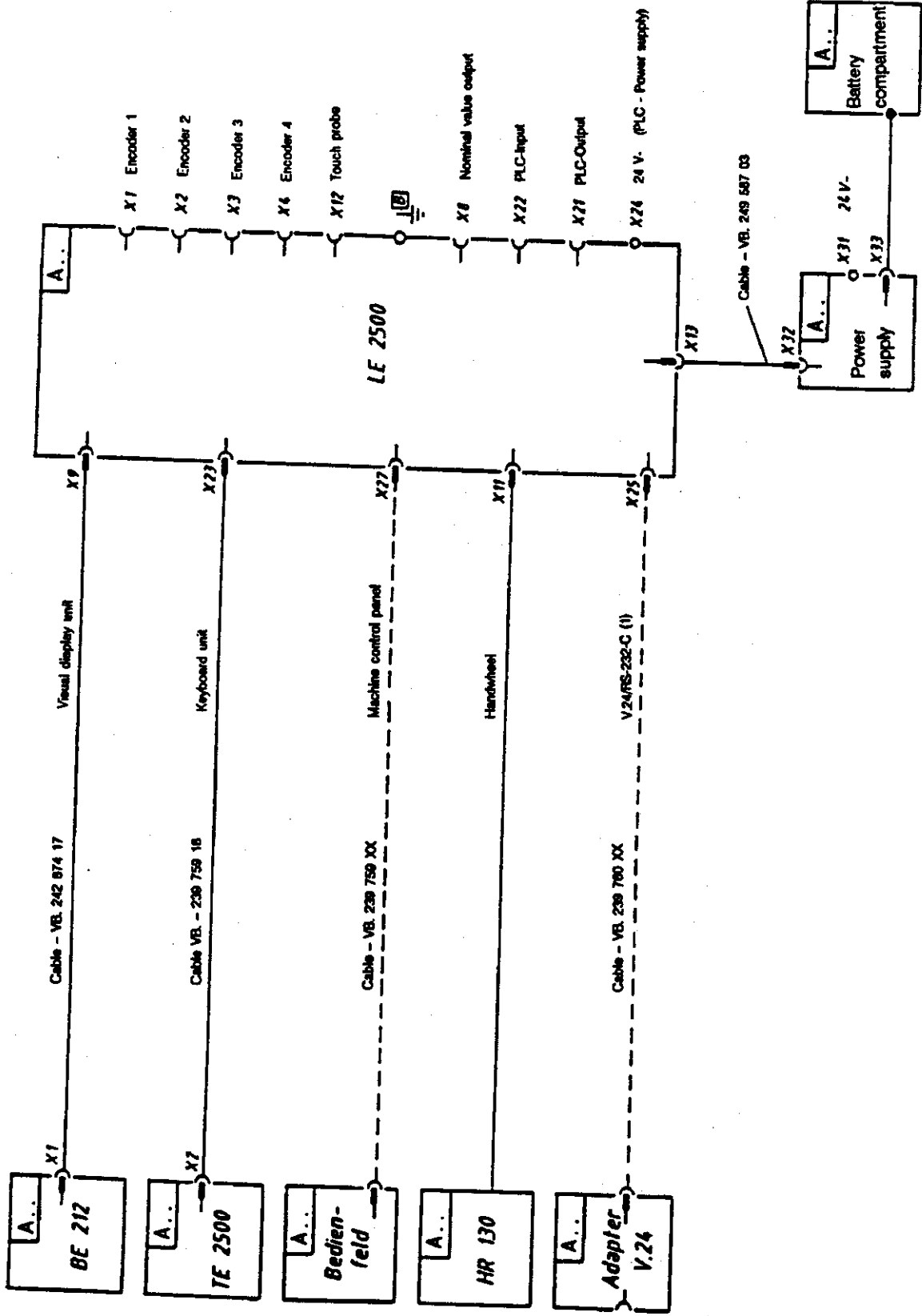



# Connections on the LE

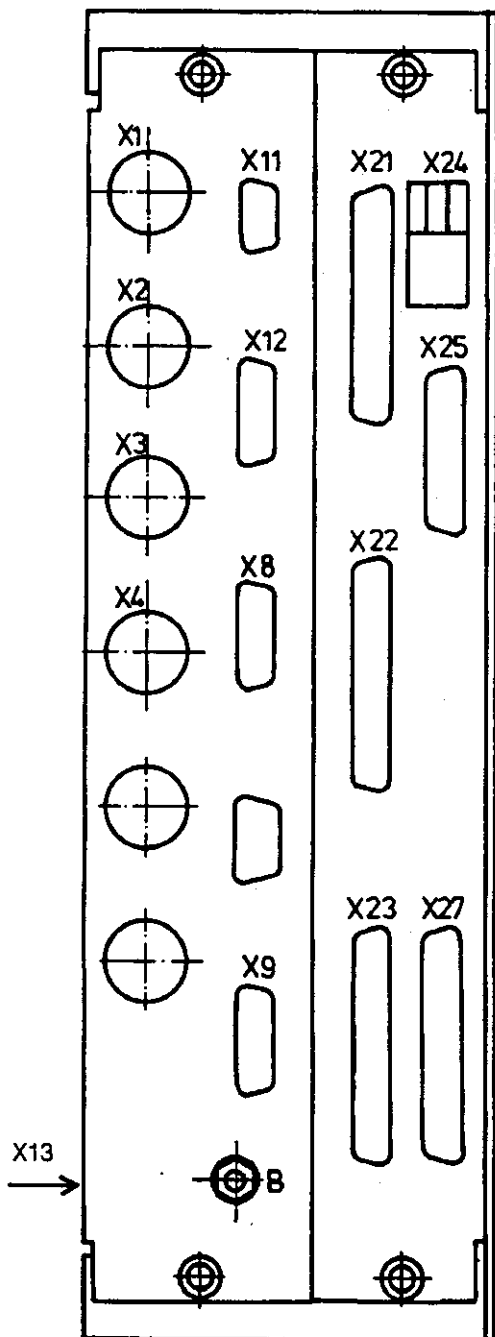

## Control loop:

- X1 = Encoder X                      Standard allocation
- X2 = Encoder Y                      (selectable via
- X3 = Encoder Z                      machine parameter)
- X4 = Encoder IV
- X8 = Nominal value output for X, Y, Z, IV (red)
- X9 = BE 212 Visual display unit (blue)
- X11 = HR 130 Electronic handwheel (red)
- X12 = TS 120/TS 111/TS 511 Touch probe (yellow)

## Processor:

- X21 = PLC output (red)
- X22 = PLC input (yellow)
- X23 = TE 2500 TNC keyboard (blue)
- X24 = 24 V DC Power supply for PLC
- X25 = RS-232-C/V.24 Data interface (red)
- X27 = Machine control panel (green)

## Power supply:

- X13 = 24 V DC power supply for LE
- B = Signal ground

# Connections on the LE

## X1, X2, X3, X4 Encoder 1, 2, 3, 4 (sinusoidal signal input)

Flange socket, female (9-pole)

Contact No.	Allocation
1	0 <sup>0+</sup>
2	0 <sup>0-</sup>
5	90 <sup>0+</sup>
6	90 <sup>0-</sup>
7	RI+
8	RI-
3	+ 5 V(U <sub>P</sub> )
4	0 V (U <sub>N</sub> )
9	Internal screen
Housing	External screen = Unit housing

## X9 Visual display unit BE 212

Flange socket, female (15-pole)

Contact No.	Allocation
1, 8	0 V power supply
4	+ 12 V power supply
9	V SYNC
10	H SYNC
13	VIDEO
Housing	External screen = Unit housing
2, 7, 14, 15	do not assign
11	0 V-signal
12	0 V
3	Brightness display screen C3
5	Brightness display screen C2
6	Brightness display screen C1

## X11 Electronic handwheel HR 330/HR 130

Flange socket, female (9-pole)

Contact No.	Allocation
1, 3, 5	not assigned
2	0 V
4	+ 12 V
6	DTR
7	TXD
8	RXD
9	DSR
Housing	Screen

1) Externally supplied reference potential for the reference pulse inhibitor  
2) Probing stylus at rest position means signal at high

## X8 Nominal value output 1, 2, 3, 4

Flange socket, female (15-pole)

Contact No.	Allocation
1	Analogue output 1
3	Analogue output 2
5	Analogue output 3
7	Analogue output 4
4	Analogue output 5
8	Analogue output axis S
9	0 V Analogue output 1
11	0 V Analogue output 2
13	0 V Analogue output 3
14	0 V Analogue output 4
6	0 V Analogue output 5
15	0 V Analogue output S
Housing	External screen = Unit housing
2, 10, 12	do not assign

## X13 Power supply for logic unit (LE)

Terminal

Terminal	Allocation
1	+ 5 V potential-free
2	do not assign
3	+ 12 V
4	+ 5 V
5	0 V
6	+ 15 V
7	Reset
8	UBatt
9	- 15 V
10	+ 12 V BE
11	0 V BE
12	0 V potential-free

## X12 Touch probe system TS 120 (TS 111/TS 511 only via cable adapter)

Flange socket, female (male) 15-pole

Contact No.	Allocation
1	0 V screen
3	Standby
4	Start
5	+ 15 V
6	+ 5 V (U <sub>P</sub> )
7	Battery warning
8	0 V (U <sub>N</sub> )
9	Trigger signal
10	Trigger signal <sup>2)</sup>
2, 11 to 15	do not assign

# Connections on the LE

## X21 PLC-output

Flange socket, female (37-pole)

Contact No.	Allocation
1	O0 <sup>3)</sup>
2	O1 <sup>3)</sup>
3	O2 <sup>3)</sup>
4	O3 <sup>3)</sup>
5	O4 <sup>3)</sup>
6	O5 <sup>3)</sup>
7	O6 <sup>3)</sup>
8	O7 <sup>3)</sup>
9	O8
10	O9
11	O10
12	O11
13	O12
14	O13
15	O14
16	O15
17	O16
18	O17
19	O18
20	O19
21	O20
22	O21
23	O22
24	O23
25	O24 <sup>2)</sup>
26	O25 <sup>2)</sup>
27	O26 <sup>2)</sup>
28	O27 <sup>2)</sup>
29	O28 <sup>2)</sup>
30	O29 <sup>2)</sup>
31	O30 <sup>2)</sup>
32	do not assign
33	0 V PLC (Test)
34	Control operational
35, 36, 37	24 V via external EMERGENCY STOP disconnectible (PLC - supply <sup>1)</sup> )
Housing	External screen

## X22 PLC-input

Flange socket, female (37-pole)

Contact No.	Allocation
1	I0
2	I1
3	I2
4	I3 Feedback signal for test "Control operational"
5	I4
6	I5
7	I6
8	I7
9	I8
10	I9
11	I10
12	I11
13	I12
14	I13
15	I14
16	I15
17	I16
18	I17
19	I18
20	I19
21	I20
22	I21
23	I22
24	I23
25	I24
26	I25
27	I26
28	I27
29	I28
30	I29
31	I30
32	I31
33, 34	do not assign
35, 36, 37	0 V (PLC) <sup>4)</sup>
Housing	External screen

<sup>1)</sup> Power for disconnectible outputs can also be supplied via connector X24, pin 1

<sup>2)</sup> cannot be switched off via external EMERGENCY OFF

A0... A23 can be switched off via external EMERGENCY OFF

<sup>3)</sup> also on X27, machine control panel

<sup>4)</sup> Connector X24, pin 3 can also be selected as the 0 V connection

# Connections on the LE

## X23 TNC-Keyboard unit (TE 2500)

Flange socket, female (37-pole)

Contact No.	Allocation	
1	RL0	for key matrix
2	RL1	
3	RL2	
4	RL3	
5	RL4	
6	RL5	
7	RL6	
8	RL7	
9	RL8	
10	RL9	
11	RL10	
12	RL11	
13	RL12	
14	RL13	
15	RL14	
16	RL15	
17	RL16	
18	RL17	
19	RL18	
20	SL0	for key matrix
21	SL1	
22	SL2	
23	SL3	
24	SL4	
25	SL5	
26	SL6	
27	SL7	
28	RL19	
29	RL20	
30	do not assign, internal 0 V	
31	RL21	
32	RL22	
33	RL23	
34	spindle override (wiper)	
35	Feed rate override (wiper)	
36	+ 5 V override potentiometer	
37	0 V override potentiometer	
Housing	External screen	

## X25 Data Interface V.24/RS-232-C

Flange socket, female (25-pole)

Contact No.	Allocation
1	Screen
2	RxD
3	TxD
4	CTS
5	RTS
6	DTR
7	GND
8 to 19	do not assign
20	DSR
21 to 25	do not assign
Housing	External screen

## X24 Power supply for the PLC

Terminals

Terminal No.	Allocation
1	+ 24 V via EMERGENCY STOP disconnectible
2	+ 24 V via EMERGENCY STOP disconnectible
3	0 V

# Connections on the LE

## X27 Machine operating panel

Flange socket, female (37-pole)

Contact No.	Allocation
1	I128
2	I129
3	I130
4	I131
5	I132
6	I133
7	I134
8	I135
9	I136
10	I137
11	I138
12	I139
13	I140
14	I141
15	I142
16	I143
17	I144
18	I145
19	I146
20	I147
21	I148
22	I149
23	I150
24	I151
25	do not assign
26	O0
27	O1
28	O2
29	O3
30	O4
31	O5
32	O6
33	O7
34	0 V (PLC)
35	0 V (PLC)
36	+ 24 V (PLC) output
37	+ 24 V (PLC) output
Housing	External screen

# Connections on the Power supply

## X31 Power supply (Input)

The DC Power Supply requires its own 24 V DC voltage according to VDE 0551.

Contact No.	Allocation
1	+ 24 V
2	0 V

## X32 Power supply (Output for LE 2500)

Contact No.	Allocation
1	0 V
2	+ 5 V
3	+ 12 V
4	+ 15 V
5	- 12 V
6	- 15 V
7	Reset
8	+U <sub>Batt</sub>
13a	0 V/BE
14a	+ 12 V/BE
13b	0 V* 1
14b	+ 5 V* 1
9	0 V (zu + 24 V)
10	+ 24 V

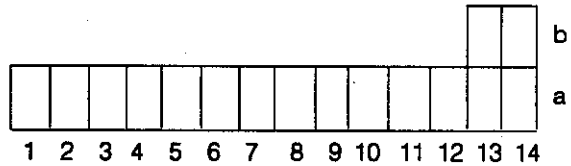

## X33 Buffer Battery

Contact No.	Allocation
1	-U <sub>Batt</sub>
2	+U <sub>Batt</sub>

# Connections on the TE

## X2 for connection to logic unit LE 2500

Flange socket, female (37-pole)

Contact No.	Allocation
1	RL0
2	RL1
3	RL2
4	RL3
5	RL4
6	RL5
7	RL6
8	RL7
9	E128
10	E129
11	E130
12	E131
13	E132
14	E133
15	E134
16	E135
17	E136
18	E137
19	E138
20	SL0
21	SL1
22	SL2
23	SL3
24	SL4
25	SL5
26	SL6
27	SL7
28	E139
29	E140
30	do not assign, internal 0 V
31	E141
32	E142
33	E143
34	Spindle override (wiper)
35	Feed rate override (wiper)
36	+ 5 V override potentiometer
37	0 V override potentiometer

for key matrix

for key matrix

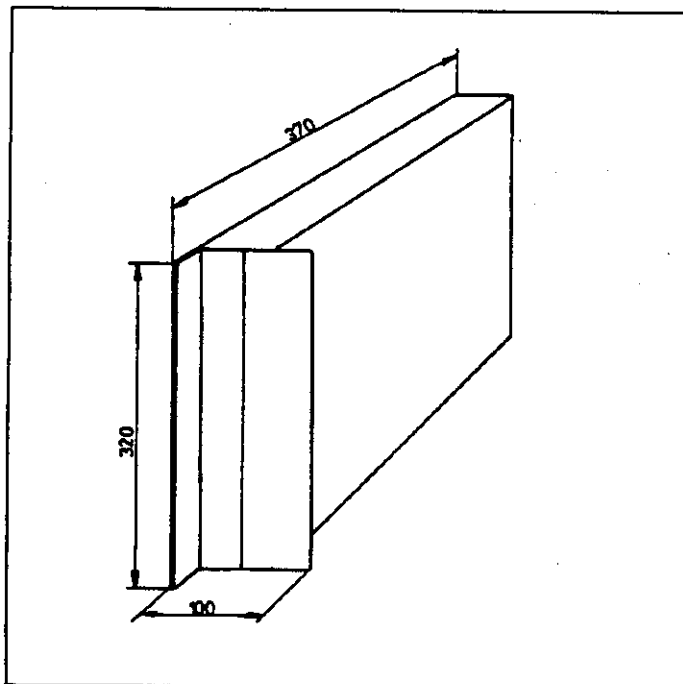

LE 2500 Logic unit

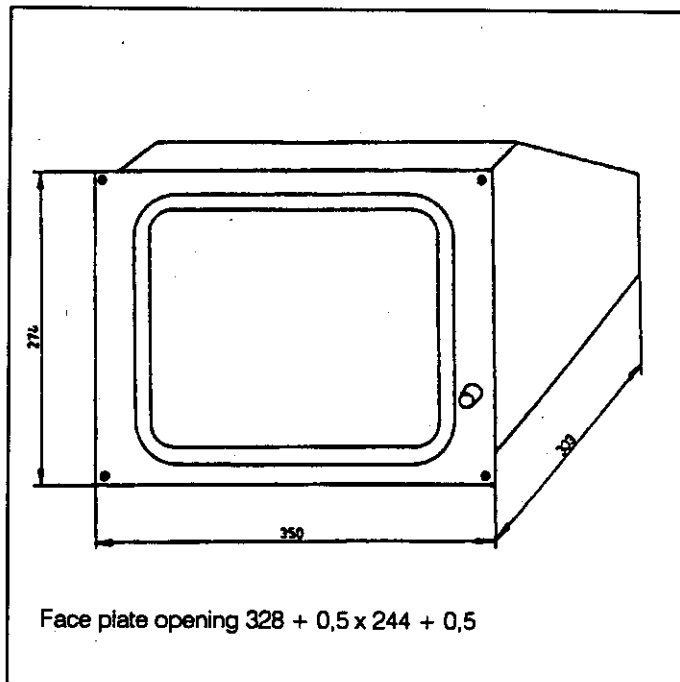

BE 212 Visual display unit

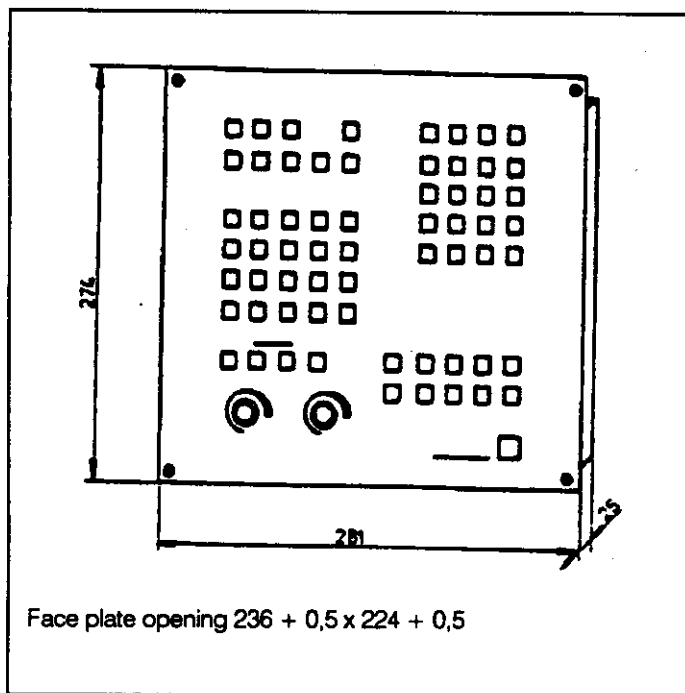

TE 2500 Keyboard unit



# Grounding plan

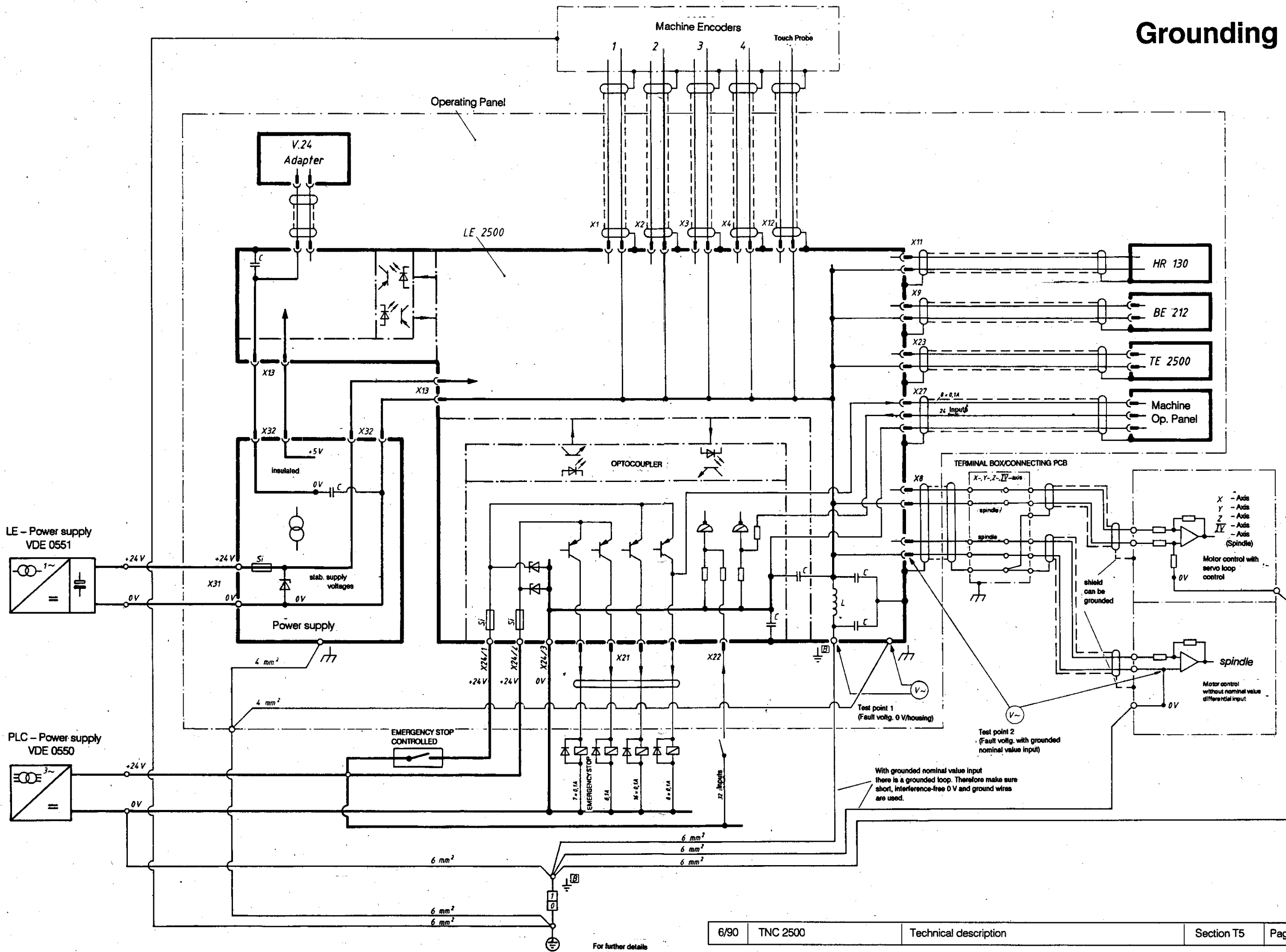

For further details see Operating Manual

# Chapter overview

	Section	Page
<b>Machine parameters</b>	C1	1
General	C1	1
Edit protection	C1	1
User-parameters	C1	1
Entry values	C1	1
Categories	C1	4
Complete list	C1	5
Encoders and machine axes	C1	5
Positioning	C1	9
Operating and speed precontrol	C1	12
Operation with trailing error (lag)	C1	13
Spindle control	C1	14
Integral PLC	C1	16
Adaptation of data interface	C1	19
Measurement using the 3D touch probe system	C1	21
Tapping	C1	22
Display and programming	C1	23
Colour distribution for colour screen	C1	25
Machining and program run	C1	27
Hardware	C1	29

In order that the machine can correctly execute programmed instructions, the control must know specific machine data, e.g. traverses, accelerations etc.

These data are determined by the machine manufacturer and entered into the control via machine parameters.

Moreover, certain functions which can be made possible with the TNC, but are only characteristic of specific machine types, can be activated via machine parameters e.g. an automatic toolchanger.

## Edit parameters for machine parameters

Access to the machine parameters is locked via a code number. Two code numbers are used:

**95148** for entry and editing of the complete machine parameter list.

**123** for access to the section of machine parameters which can be edited by the enduser.

## User-parameters

In the MOD-function "User-parameters", certain machine parameters can be easily accessed, e.g. to change over from HEIDENHAIN plain language to ISO. The user-parameters being accessible via the MOD-function are determined by the machine tool manufacturer.

## Entry values

Entry values are e.g. numbers 0 to 1 for the selection of functions, signs or counting direction and numerical values for feeds, traverses, etc.

Furthermore, there are summated entry values which are calculated through the combination of several functions (multiple functions, see next page).

### Entry values for multiple functions of machine parameters

Max. 8 functions can be activated by bit 0-7. The entry value results from the sum of the decimal numerical values of the bits for the functions requested.

Bit 0-7	7	6	5	4	3	2	1	0
Value	$2^7$	$2^6$	$2^5$	$2^4$	$2^3$	$2^2$	$2^1$	$2^0$
Decimal numerical value	128	64	32	16	8	4	2	1

### Example: Determination of entry values for MP5020.

Function	Parameter No.	Entry values															
Data format and transmission stop for data interface RS-232-C/V.24	5020																
	Bit																
7 or 8 databits	0	+ 0 ⇒ 7 databits (ASCII code with 8 <sup>th</sup> bit = parity) + 1 ⇒ 8 databits (ASCII code with 8 <sup>th</sup> bit = 0 and 9 <sup>th</sup> bit = parity)															
Block check character	1	+ 0 ⇒ BCC-character optional + 2 ⇒ BCC-character not control character															
Transmission stop through RTS	2	+ 0 ⇒ inactive + 4 ⇒ active															
Transmission stop through DC3	3	+ 0 ⇒ inactive + 8 ⇒ active															
Character parity even or odd	4	+ 0 ⇒ even + 16 ⇒ odd															
Character parity required	5	+ 0 ⇒ not required + 32 ⇒ required															
	6/7	<table border="1"> <tr> <td>7</td> <td>6</td> <td></td> </tr> <tr> <td>0</td> <td>0</td> <td>1 1/2 Stop bits</td> </tr> <tr> <td>0</td> <td>1</td> <td>2 Stop bits</td> </tr> <tr> <td>1</td> <td>0</td> <td>1 Stop bit</td> </tr> <tr> <td>1</td> <td>1</td> <td>1 Stop bit</td> </tr> </table>	7	6		0	0	1 1/2 Stop bits	0	1	2 Stop bits	1	0	1 Stop bit	1	1	1 Stop bit
7	6																
0	0	1 1/2 Stop bits															
0	1	2 Stop bits															
1	0	1 Stop bit															
1	1	1 Stop bit															
		Bit 6: + 64															
		Bit 7: + 128															

The entry value for MP5020 is calculated by adding the entry values of the desired functions.

For instance, the following functions are required:

Function	Bit	Entry value
7 databits	0	+ 0
BCC not to be control character	1	+ 2
No transmission stop through RTS	2	+ 0
Transmission stop through DC3 requested	3	+ 8
Character parity even	4	+ 0
Character parity required	5	+ 32
1 Stopbit	6	+ 0
	7	+ 128
Sum of entry values:		170

If 170 is entered into MP 5020, the above functions are active.

The machine parameters are divided into specific groups.

Parameter numbers are structured such, that extensions of the list can be made without problems.

The following list contains all machine parameters for the TNC 246, TNC 411 and TNC 415. In contrast to the TNC 246, more machine parameters can be entered for the versions TNC 411/TNC 415.

Machine parameters applicable to the TNC 246 are marked with .

		Page
0-0999	Encoders and machine axes: Allocation, Evaluation, Corrections	5
1000	Positioning	8
1400	Operation with speed precontrol	12
1700	Operation with trailing error (lag)	13
3000	Spindle control	14
4000	Integral PLC	16
5000	Adaptation of the data interface <sup>1)</sup>	19
6000	Measurement with the 3D touch probe system <sup>1)</sup>	21
7100	Tapping	22
7200	Display and programming <sup>2)</sup>	23
7400	Machining and program run	27
7600	Hardware	29

<sup>1)</sup> = selectable via code number **123**

<sup>2)</sup> = selectable via code number **123** (with exception of MP 7250 and MP 7251; these parameters should only be selected via the code number 95148 oder 105 296).

## Encoders and machine axes

Determination of entry values **MP 10, MP 30, MP 40, MP 50**

	Bit		Bit
X	0	+ 0 ⇒ not assigned	0
	1	+ 1 ⇒ assigned	
Y	1	+ 0 ⇒ not assigned	1
	2	+ 2 ⇒ assigned	
Z	2	+ 0 ⇒ not assigned	2
	4	+ 4 ⇒ assigned	
IV	3	+ 0 ⇒ not assigned	3
	8	+ 8 ⇒ assigned	

**MP 31, MP 32**

X	0 ⇒ not active
Y	1 ⇒ active
Z	0 ⇒ not active
IV	2 ⇒ active
	0 ⇒ not active
	4 ⇒ active
	0 ⇒ not active
	8 ⇒ active

Entry value: .....

Entry value: .....

Function	Parameter No.	Entry	Preliminary entry values	Optimised entry values	Corresponding MP ... of TNC 355
Axes with encoders	10	0 ... 15			
Encoder supervision	30	0 ... 15			
Supervision of encoder signal amplitude	31	0 ... 15			
Supervision of encoder signal frequency	32	0 ... 15			
Display on screen	40	0 ... 15			
Regulated axes	50	0 ... 15			
Allocation of axes to encoder inputs	X 110.0 Y 110.1 Z 110.2 IV 110.3	0 = X1 1 = X2 2 = X3 3 = X4			253 254 255 256
Allocation of analogue outputs	X 120.0 Y 120.1 Z 120.2 IV 120.3	0 = output 1 1 = output 2 2 = output 3 3 = output 4			

Function	Parameter No.	Entry	Preliminary entry values	Optimised entry values	Corresponding MP ... of TNC 355
Counting direction	210	0 ... 15			
	X	+ 0 ⇒ positive + 1 ⇒ negative			20
	Y	+ 0 ⇒ positive + 2 ⇒ negative			21
	Z	+ 0 ⇒ positive + 4 ⇒ negative			22
Evaluation	IV	+ 0 ⇒ positive + 8 ⇒ negative			23
		0 ... 3			
	X	0 ⇒ 256-fold			
	Y	1 ⇒ 4-fold			
Grating period	Z	2 ⇒ 2-fold			
	IV	3 ⇒ 1-fold			
	X	0 ... 100 (µm). For connection of rotary encoders for linear measurement, places after the decimal point may also be entered. These must be a whole number multiple at 0.125 µm.			
	Y	330.0 ● 330.1 ● 330.2 ● 330.3 ●			
Axis designation	IV	0 ⇒ A1 ⇒ B 2 ⇒ C 3 ⇒ U 4 ⇒ V 5 ⇒ W			90



Function	Parameter No.	Entry	Preliminary entry values	Optimised entry values	Corresponding MP ... of TNC 355
<b>Axis corrections</b> Backlash compensation	X	-1.000 ... +1.000 [mm]			36
	Y				37
	Z				38
	IV				39
<b>Correction factor for linear compensation</b>	X	-1.000 ... +1.000 [mm/m]			40
	Y				41
	Z				42
	IV				43
<b>Enable for non-linear axis error compensation</b>		0 ... 15			
	X	+ 0 → inactive			20
	Y	+ 1 → active			21
	Z	+ 0 → inactive			22
	IV	+ 2 → active			
		+ 0 → inactive			
		+ 4 → active			
		+ 0 → inactive			
		+ 8 → active			23

Function	Parameter No.	Entry	Preliminary entry values	Optimised entry values	Corresponding MP .... of TNC 355		
<b>Software limit switch ranges</b> Basic setting after power-on; Activation via PLC; M2817 = 0, M2816 = 0; Strobe marker M2824 ;	X+	Linear axis: -30 000,000 ... +30 000,000 [mm] Rotary axis: -30 000,000 ... +30 000,000 [°]			44		
	Y+				46		
	Z+				48		
	IV+				50		
	X-	920.0				45	
	Y-	920.1				47	
	Z-	920.2				49	
	IV-	920.3				51	
	Activation via PLC; M2817 = 0, M2816 = 1; Strobe marker M2829	X+					
		Y+					911.0
		Z+					911.1
		IV+					911.2
	Activation via PLC; M2817 = 1, M2816 = 0; Strobe marker M2824	X-					
Y-		921.0					
Z-		921.1					
IV-		921.2					
	X+						
	Y+					912.0	
	Z+					912.1	
	IV+					912.2	
	X-						
	Y-					922.0	
	Z-					922.1	
	IV-					922.2	
Datum for positioning blocks with M92:	X	Linear axis: -30 000,000 ... +30 000,000 [mm] Rotary axis: -30 000,000 ... +30 000,000 [°]			186		
	Y				187		
	Z				188		
	IV				189		

Function	Parameter No.	Entry	Preliminary entry values	Optimised entry values	Corresponding MP ... of TNC 355
Rapid traverse	X	Linear axis: 80 ... 29 998 [mm/min]			0
	Y	Rotary axis: 80 ... 29 998 [mm/min]			1
	Z	Linear axis: 80 ... 29 998 [mm/min]			2
	IV	Rotary axis: 80 ... 29 998 [°/min]			3
Manual feed	X	Linear axis: 80 ... 29 998 [mm/min]			4
	Y	Rotary axis: 80 ... 29 998 [mm/min]			5
	Z	Linear axis: 80 ... 29 998 [mm/min]			6
	IV	Rotary axis: 80 ... 29 998 [°/min]			7
Position window	X	Linear axis: 0,001 ... 2,000 [mm]			58
	Y	Rotary axis: 0,001 ... 2,000 [mm]			
	Z	Linear axis: 0,001 ... 2,000 [mm]			
	IV	Rotary axis: 0,001 ... 2,000 [°]			192
Polarity of nominal value voltage with positive traversing direction	1040	0 ... 15			
	X	Bit 0	+ 0 ⇒ positive + 1 ⇒ negative		24
	Y	1	+ 0 ⇒ positive + 2 ⇒ negative		25
	Z	2	+ 0 ⇒ positive + 4 ⇒ negative		26
Analogue voltage at rapid	IV	3	+ 0 ⇒ positive + 8 ⇒ negative		27
	X	1050.0	+ 4,5 ... + 9 [V]		52
	Y	1050.1			300
Acceleration	Z	1050.2			301
	IV	1050.3			302
	X	1060.0	0,001 ... 3,0 [m/s <sup>2</sup> ]		54
	Y	1060.1			297
Radial acceleration	Z	1060.2			298
	IV	1060.3			299
		1070	0,001 ... 3,0 [m/s <sup>2</sup> ]		55

Function	Parameter No.	Entry	Preliminary entry values	Optimised entry values	Corresponding MP ... of TNC 355
Integral factor	X	0 ... 65 535			28
	Y				29
	Z				30
	IV				31
Standstill supervision	1110	0,001 ... 30 [mm]			169
Movement supervision	1140	0,03 ... 10 [V]			234
Delay for cut-out of residual nominal value voltage when "Positioning error" displayed	1150	0 ... 65,535 [s]			185
Automatic drive offset adjustment	1220	1 ... 65 535 [in units of 20 ms] 0 = No automatic adjustment			252
<b>Approaching the reference marks</b>					
Traversing direction when approaching reference marks	1320	0 ... 15  + 0 ⇒ positive + 1 ⇒ negative + 0 ⇒ positive + 2 ⇒ negative + 0 ⇒ positive + 4 ⇒ negative + 0 ⇒ positive + 8 ⇒ negative			16
	Bit 0				17
	Y				18
	Z				19
Speed when approaching reference marks	1330.0	80 ... 29 998 [mm/min]			8
	X				9
	Y				10
	Z				11
Speed when leaving reference marks For employment of ROD see MP 1350	1331.0	80 ... 500 [mm/min]			
	X				
	Y				
	Z				

Function	Parameter No.	Entry	Preliminary entry values	Optimised entry values	Corresponding MP ... of TNC 355
Axis sequence for reference mark approach	1340.0	0 ... 4			59
	1340.1 1340.2 1340.3	0 ⇒ No Ref-approach 1 ⇒ X 2 ⇒ Y 3 ⇒ Z 4 ⇒ IV			
Selection of function of reference mark approach	X	0 ⇒ Encoder with distance-coded reference marks			
	Y	1 ⇒ Encoder w/o distance coded ref. marks			
	Z	2 ⇒ Special (using rotary encoder)			
	IV				
	V				
Operation with speed precontrol	1390.0	0 ⇒ on 1 ⇒ off			60

### Switch dogs "reference end position"

The reference marks can be approached either manually with the axis direction keys or automatically with the start-key. The entry of a key number of manual override as formerly used with TNC contouring is void. The direction for the automatic reference mark approach is entered at MP 1320. In order to reverse the programmed direction in the end zone a switch dog "reference end position" is required. The switching signals "reference end position" are located at the free PLC inputs. These PLC inputs are connected via PLC software with the PLC markers M256 and M2556 to M2559. Depending on the entered values in MP 1350 the TNC behaves differently.

### Linear encoder system with distance-coded reference marks (No special procedure)

If when starting the "reference mark approach" the switch signal "reference end position" is set, the axis will travel in the opposite direction as entered in MP 1320. If the switch signal "reference end position" occurs during the automatic start-up the TNC ignores this signal. Therefore at least two reference marks have to be within the "reference end position" region. The reference marks can be evaluated either in the region of the "reference end position" or anywhere along the encoder. If at auto start the evaluation of the reference mark occurs outside of the "software limit switch region" the axis will alter evaluation go automatically onto the software limit switch.

### Special procedure when using rotary encoders for linear measurement (Special procedure active)

The axis travels automatically at the preselected feed rate (MP 1330) onto the switch dog "reference end position". The axis then starts with reduced speed (MP 1331) in the opposite direction and after leaving the region "reference end position" will evaluate the first reference mark and then stop. If the axis is in the region "reference end position" when starting, the axis will immediately traverse with reduced speed (MP 1331) in the opposite direction as entered for MP 1320.

## Operation with speed precontrol

Function	Parameter No.	Entry	Preliminary entry values	Optimised entry values	Corresponding MP ... of TNC 355
Position supervision for operation with speed precontrol Erasable EMERGENCY STOP	1410				
	1420	0,001 ... 30 000 [mm]			5657
Kv-factor for operation with speed precontrol	X				32
	Y				33
	Z	0,1 ... 10			34
	IV				35
Approach speed	1520	0,1 ... 10 [m/min]			53
Oscillation behaviour during acceleration	1530	0,01 ... 0,999			64

## Operation with trailing error (lag)

Function	Parameter No.	Entry	Preliminary entry values	Optimised entry values	Corresponding MP ... of TNC 355
Position supervision in trailing operation Erasable EMERGENCY STOP	1710				175
	1720	0 ... 100 [mm]			174
Kv-factor for trailing operation	1810.0	0,1 ... 10			177
	1810.1				178
	1810.2				179
	1810.3				180
Multiplication factor for Kv-factor	1820	0,001 ... 1,000			176
	1830	0 ... 100,000 [%]			181
Characteristic kink					

## Spindle control

Function	Parameter No.	Entry	Preliminary entry values	Optimised entry values	Corresponding MP ... of TNC 355
Output of spindle speed Coded	3010	0 ... 5 0 ⇒ No output of spindle speed 1 ⇒ Output only when tool number changes 2 ⇒ Output with every TOOL CALL 3 ⇒ Gear switching signal only when gear range changes 4 ⇒ Gear switching signal with every TOOL CALL 5 ⇒ Without gear switching signal			62
Analogue					
RPM code limit	3020	0 ... 01991 01991 ⇒ No limit			63
Axis halt if spindle RPM only is changed with a TOOL CALL	3030	0 ⇒ Axis halt 1 ⇒ No axis halt			214
Programming of RPM S = Opermitted (voltage value of MP 3240.1 not to be lower)	3120	0 ⇒ S = 0 Permitted 1 ⇒ S = 0 not permitted			190
Polarity of S-analogue voltage	3130	0 ⇒ M03; positive voltage M04; negative voltage 1 ⇒ M03; positive voltage M04; negative voltage 2 ⇒ M03 and M04; pos. volt. 3 ⇒ M03 and M04; neg. volt.			172
Analogue voltage for gear ranges	3210.0 3210.1 3210.2 3210.3 3210.4 3210.5 3210.6 3210.7	0 ... 9,999 [V]			



Function	Parameter No.	Entry	Preliminary entry values	Optimised entry values	Corresponding MP ... of TNC 355
Control range for S-analogue					
S-Analogue with S-override max. output voltage	3240.0	0 ... 9,999 [V]			87
Minimum voltage for S-analogue output	3240.1	0 ... 9,999 [V]			184
Nominal value voltage for spindle drive with gear change	3240.2	0 ... 9,999 [V]			70
Limitation of S-override	3310.0	0 ... 150 [%]			88 89
	3310.1				
Ramp gradient for S-analogue	3410.0	0 ... 1,999 [V/ms]			168
Ramp gradient for S-analogue with "Tapping" cycle (is compared to acceleration ramp of tool axis. The flatter ramp is the decisive value).	3410.1	0 ... 1,999 [V/ms]			
Kv (speed amplification)	0	0.1 ... 10			238
	1				
	2				
	3				
	4				
	5				
	6				
	7				
S-analogue output rpm range for gear ranges	3440.0	0 ... 99 999,999 [U/rpm.]			78 79 80 81 82 83 84 85
	3440.1				
	3440.2				
	3440.3				
	3440.4				
	3440.5				
	3440.6				
	3440.7				
RPM if marker 2501 is set	3510.0	0 ... 99 999,999 [rpm] The rotating direction is always positive.			258
	3510.1				
	3510.2				
	3510.3				
	3510.4				
	3510.5				
	3510.6				
	3510.7				

## Integral PLC

Function	Parameter No.	Entry	Preliminary entry values	Optimised entry values	Corresponding MP ... of TNC 355
PLC: program from RAM or from EPROM	4010	+ 0 ⇒ EPROM-operation + 1 ⇒ RAM-operation			77
	4060.0	0 ... 65 535 (in units of 65 536 µm)			159
	4060.1				160
	4060.2				161
	4060.3				162
Automatic lubrication	X Y Z IV				
PLC: programmed duration for timers 0 – 47	4110.0	0 ... 65 535 (in units of 24 ms)			110 – 125
	4110.1				193 – 208
	4110.2				264 – 299
	4110.3				
	4110.4				
	4110.5				
	4110.6				
	4110.7				
	4110.8				
	4110.9				
	4110.10				
	4110.11				
	4110.12				
	4110.13				
	4110.14				
	4110.15				
	4110.16				
	4110.17				
	4110.18				
	4110.19				
	4110.20				
	4110.21				
	4110.22				
	4110.23				
	4110.24				
	4110.25				
	4110.26				
	4110.27				
	4110.28				
	4110.29				
	4110.30				
	4110.31				
	4110.32				
	4110.33				
	4110.34				
	4110.35				
4110.36					

Function	Parameter No.	Entry	Preliminary entry values	Optimised entry values	Corresponding MP ... of TNC 355
	4110.37 4110.38 4110.39 4110.40 4110.41 4110.42 4110.43 4110.44 4110.45 4110.46 4110.47				
PLC: Counter preset value for counters 0 - 31	4120.0 4120.1 4120.2 4120.3 4120.4 4120.5 4120.6 4120.7 4120.8 4120.9 4120.10 4120.11 4120.12 4120.13 4120.14 4120.15 4120.16 4120.17 4120.18 4120.19 4120.20 4120.21 4120.22 4120.23 4120.24 4120.25 4120.26 4120.27 4120.28 4120.29 4120.30 4120.31	0 ... 65 535 (in units of 24 ms)		280 - 295	94 - 108
PLC: 32 positioning values for PLC-positioning	4210.0 4210.1	-30 000,000 ... + 30 000,000 [mm]			126 - 156

Function	Parameter No.	Entry	Preliminary entry values	Optimised entry values	Corresponding MP ... of TNC 355
	4210.2 4210.3 4210.4 4210.5 4210.6 4210.7 4210.8 4210.9 4210.10 4210.11 4210.12 4210.13 4210.14 4210.15 4210.16 4210.17 4210.18 4210.19 4210.20 4210.21 4210.22 4210.23 4210.24 4210.25 4210.26 4210.27 4210.28 4210.29 4210.30 4210.31				
PLC: Datum shift	X Y Z IV	± 30.000 [mm]			
PLC: Datum shift	X Y Z IV	± 30.000 [mm]			
PLC: Datum shift	X Y Z IV	± 30.000 [mm]			

Function	Parameter No.	Entry	Preliminary entry values	Optimised entry values	Corresponding MP .... of TNC 355
Feed rate for PLC-positioning X Y Z IV	4220.0	80 ... 29 998 [mm/min]			163
	4220.1				164
	4220.2				165
	4220.3				166
Setting of a binary number using 112 markers	4310.0	PLC markers 2192..2207 2208..2223 2224..2239 3200..3215 3216..3231 3232..3247 3249..3263			158
	4310.1				249
	4310.2				250
	4310.3				209
	4310.4				210
	4310.5				211
4310.6	212				
Characters for "Transfer blockwise" Characters for program beginning and end The character for program end also applies to the "standard data interface"	5010.0	0 ... 65 535			71
	5010.1	0 ... 65 535			218
	5010.2	0 ... 65 535			219
	5010.3	0 ... 12 079			220
	5010.4	0 ... 12 079			221
	5010.5	0 ... 12 079			214
Data format and transmission stop for data interface RS-232-C/V.24  7 or 8 data bits	5020				222
	Bit 0	+ 0 ⇒ 7 data bits (ASCII-code with 8 <sup>th</sup> bit = parity) + 1 ⇒ 8 data bits (ASCII-code with 8 <sup>th</sup> bit = 0 and 9 <sup>th</sup> bit = parity)			

Function	Parameter No.	Entry	Preliminary entry values	Optimised entry values	Corresponding MP ... of TNC 355										
Block/Check/Character	1	+ 0 ⇒ BCC-character optional + 2 ⇒ BCC-character not control character													
Transmission stop via RTS	2	+ 0 ⇒ inactive + 4 ⇒ active													
Transmission stop via DC3	3	+ 0 ⇒ inactive + 8 ⇒ active													
Character parity even or odd	4	+ 0 ⇒ inactive + 16 ⇒ active													
Character parity required	5	+ 0 ⇒ even + 32 ⇒ odd													
Number of stop bits	6/7	<table style="border-collapse: collapse; margin-left: 20px;"> <tr> <td style="border-right: 1px solid black; padding-right: 5px;">7</td> <td style="padding-left: 5px;">6</td> </tr> <tr> <td style="border-right: 1px solid black; padding-right: 5px;">0</td> <td style="padding-left: 5px;">0</td> </tr> <tr> <td style="border-right: 1px solid black; padding-right: 5px;">0</td> <td style="padding-left: 5px;">1</td> </tr> <tr> <td style="border-right: 1px solid black; padding-right: 5px;">1</td> <td style="padding-left: 5px;">0</td> </tr> <tr> <td style="border-right: 1px solid black; padding-right: 5px;">1</td> <td style="padding-left: 5px;">1</td> </tr> </table> 1 1/2 Stop bits Bit 6: + 64 2 Stop bits Bit 6: + 64 1 Stop bits Bit 7: + 128 1 Stop bits Bit 7: + 128	7	6	0	0	0	1	1	0	1	1			
7	6														
0	0														
0	1														
1	0														
1	1														
Operating mode data interface RS-232-C/V 24	5030	0 ⇒ "Standard data interface" 1 ⇒ "Transfer blockwise"			223										

## Measurement using the 3D-Touch probe system (Accessible via Code No. 123)

Function	Parameter No.	Entry	Preliminary entry values	Optimised entry values	Corresponding MP ... of TNC 355
Selection of touch probe system	6010	0 ⇒ Cable transmission 1 ⇒ Infra-red transmission			171
Touch probe system: probing speed	6120	80 ... 3000 [mm/min]			215
Touch probe system: Measuring range	6130	0 ... 19 999,999 [mm]			216
Touch probe system: Safety clearance above measuring point for automatic probing	6140	0 ... 19 999,999 [mm]			235
Touch probe system: Rapid traverse for probing	6150	180 ... 29 998 [mm/min]			251

## Tapping

Function	Parameter No.	Entry	Preliminary entry values	Optimised entry values	Corresponding MP ... of TNC 355
Minimum feed rate override	7110.0	0 ... 150 [%]			182
Maximum feed rate override	7110.1	0 ... 150 [%]			183
Dwell time for spindle rotation change	7120.0	0 ... 65,535 [s]			67
Advanced switch point (only active with BCD-output of spindle rpm)	7120.1	0 ... 65,535 [s]			73
Spindle slow-down time after reaching total hole depth	7120.2	0 ... 65,535 [s]			



Display and programming (\* Accessible via Code No. 123)

Function	Parameter No.	Entry	Preliminary entry values	Optimised entry values	Corresponding MP ... of TNC 355
Programming station	7210 *	0 → Control 1 → Programming station: PLC active 2 → Programming station: PLC inactive			170
Block number increment	7220*	0 ... 255			
Inhibit HEIDENHAIN/ISO	7222	0 → Selection via MOD 1 → only HEIDENHAIN dialogue 2 → only ISO G-codes			
Dialogue language German/English	7230 *	0 → First dialogue language 1 → Second dia. lang. (English)			92
PGM entry inhibit at PGM-No. = Manufacturer cycle No.	7240 *	0 → inhibited 1 → uninhibited			
Inhibit HEIDENHAIN- cycles 1...15	7245.0	0 ... 65 535 With entry of "0", no cycle inhibited			
Inhibit HEIDENHAIN- cycles 16...31	7245.1	0 ... 65 535 With entry of "0", no cycle inhibited			
Difference between Q-Parameter numbers for "DLG-DEF"-block and "DLG-CALL"-block in user-cycle	7250	0 ... 99 0 "DLG CALL" blocks only			263
Number of global Q-parameters which are transferred from a user-cycle to program called	7251	0 ... 100 With entry of 40, Q-parameters Q60 ... Q99 global			262
Central tool file	7260*	0 → No central tool file 1 ... 99 = Central tool file Entry value = Number of tool pockets			225
Display of current feed rate before start in <b>MANUAL</b> (in all axes same feed rate i.e. smallest programmed feed rate)	7270*	0 → No display 1 → display			167
Decimal character	7280*	0 → Decimal comma 1 → Decimal point			
Decimal character	7290*	0 → 1 μm 1 = → 5 μm			65
Erasure of status display with M02, M30 and program end	7300*	0 → Status display not to be erased 1 → Status display to be erased			173

**Display and programming** (\* Accessible via Code No. 123)

Function	Parameter No.	Entry	Preliminary entry values	Optimised entry values	Corresponding MP ... of TNC 355
Depiction of graphics in 3 planes	7310* Bit	0	0 ⇒ German standard projection + 1 ⇒ American standard projection		
		1			
8 ⇒ without gear switching signal					
Assignment of machine parameters to the 16 user-parameters	7330.0	Required machine parameter number			
	7330.1				
	7330.2				
	7330.3				
	7330.4				
	7330.5				
	7330.6				
	7330.7				
	7330.8				
	7330.9				
	7330.10				
	7330.11				
	7330.12				
	7330.13				
	7330.14				
	7330.15				

**Machining and program run** (\* Accessible via Code No. 123)

Function	Parameter No.	Entry	Preliminary entry values	Optimised entry values	Corresponding MP ... of TNC 355
"Scaling factor" cycle effective for 2 or 3 axes	7410*	0 ⇒ 3 axes 1 ⇒ in working plane			213
Contour pocket cycles	7420*				241
Cycle "Rough-out": Milling direction for outline milling of contour	Bit 0	+ 0 ⇒ Outline mill pockets CCW, CW for islands + 1 ⇒ Outline mill pockets CW, CCW for islands			
Cycle "Rough-out": sequence for outline milling and roughing-out	1	+ 0 ⇒ Outline mill then rough-out pocket + 2 ⇒ Rough-out pocket then outline mill			
Combining corrected and uncorrected contours	2	+ 0 ⇒ Combine corrected contours + 4 ⇒ Combine uncorrected contours			
"Rough-out" and "outline milling" up to pocket depth or for each	3	+ 0 ⇒ "Rough out" and "Outline milling" together for all infeeds + 1 ⇒ For each infeed first "Outline milling" and then "Rough out" (depending on bit 1) before the next infeed.			
Stepover factor for pocket milling	7430*	0,1 ... 1,414			93
Output of M-functions	7440*				214
Programmed stop with M06	Bit 0	+ 0 ⇒ Programmed stop with M06 + 1 ⇒ No programmed stop with M06			
Output of M89, modal cycle call	1	+ 0 ⇒ No cycle call: normal output of M89 at block beginning + 2 ⇒ Modal cycle call at block end			

Function	Parameter No.	Entry	Preliminary entry values	Optimised entry values	Corresponding MP ... of TNC 355
Axis standstill output of an M-function <b>Exceptions:</b> Axis halts with M-functions resulting in a programmed halt (such as M00, M02,...) or with a STOP or CYCL-CALL-block	Bit 2	+ 0 ⇒ Axis standstill + 4 ⇒ No axis standstill			
Constant contouring speed at corners	7460 *	0 ... 179.999 [°]			91
Display mode for axis of rotation	7470*	0 ⇒ ± 359.999° 1 ⇒ ± 30 000.000°			
Output of tool numbers or tool pocket numbers	7480 .0	0 ⇒ No output 1 ⇒ Output only when tool number changes 2 ⇒ Output of tool number with every tool call 3 ⇒ Output of tool pocket number (if MP 7260 > 0)			61
Output of the next tool number or place number	7480.1	0 ⇒ Not output 1 ⇒ Output only when tool number changes 2 ⇒ Output of tool number with every tool call 3 ⇒ Output of tool pocket number (if MP 7480.0 > 0)			

Hardware (\* Accessible via Code No. 123)

Function	Parameter No.	Entry	Preliminary entry values	Optimised entry values	Corresponding MP ... of TNC 355
Feed rate and spindle override	7620*		74		
Feed rate override if rapid traverse button is pressed in "program run"-mode	Bit 0	+ 0 ⇒ Override ineffective + 1 ⇒ Override effective			
Feed rate override in 2 %-stages or 1 %-stages	1	+ 0 ⇒ 2 %-stages + 2 ⇒ 1 %-stages			
Feed rate override if rapid traverse button and external direction buttons are pressed	2	+ 0 ⇒ Override ineffective + 4 ⇒ Override effective			
Handwheel	7640*	0 ⇒ Machine with electric handwheel 1 ⇒ Machine without electric handwheel			
Counting direction of handwheel	7650	0 ⇒ positiv 1 ⇒ negativ			
Hysteresis for electronic handwheel	7660	0 ... 65 535 [increments]			246
Memory function for direction buttons	7670	0 ... 10			
Memory function for direction buttons	7680	0 ⇒ not stored 1 ⇒ stored			68
Memory test with switch-on	7690				
RAM-Test	Bit 0	+ 0 ⇒ Test + 1 ⇒ No test			
EPROM-Test	1	+ 0 ⇒ Test + 2 ⇒ No test			

# Chapter overview

	Section	Page
<b>Introduction</b>	P1	1
<b>Operating modes</b>	P2	1
Address and exit	P2	1
Deleting a program	P2	2
Transfer of program from EPROM	P2	2
Editing	P2	3
TRACE-function	P2	5
I/O/C/T/M-address	P2	5
TRACE START	P2	5
TRACE END	P2	6
TRACE-BUFFER DISPLAYS	P2	6
Tables I/O/C/T/M	P2	6
Program translation	P2	7
Operating mode "Utilisation"	P2	7
Transfer of program	P2	8
<b>Commands</b>	P3	1
<b>Programming</b>	P3	1
Command format	P3	1
Overview of operands	P3	2
Structure of PLC-processor	P3	3
<b>Overview</b>	P3	5
Logic sequences	P3	5
Arithmetical functions	P3	6
Logic comparisons	P3	7
Shift functions	P3	8
Bit manipulation	P3	8
Load commands	P3	9
Assignments	P3	10
Preset commands	P3	10
Jump commands	P3	11
Stack operations	P3	12
<b>PLC-EPROM</b>	P4	1
Memory structure	P4	1

# Chapter overview

	Section	Page
<b>Permanently assigned memory</b>	P5	1
Markers	P5	1
Byte, Word, Doubleword	P5	20
Data transfer NC → PLC	P5	20
Data transfer PLC → NC	P5	21
Machine parameters	P5	23
<b>Error messages</b>	P6	1
Syntax errors within a command line	P6	1
Syntax errors related to program	P6	1
Timing errors	P6	2

# Introduction

The PLC of the TNC 2500 have been substantially extended with regard to available functions. A large number of operations, especially intended for word-processing (previously only 1 Bit-processing), have been introduced. However, it should be noted that any necessary messages are forfeited by the number of the available commands. Due to the extension of the commands available, it depends on the expertise of the programmer to optimise the full usage of the commands which are offered. The PLC processing time is 24 ms for TNC 2500.



The control offers the possibility of both programming and subsequently testing the PLC-program directly at the machine.

The various PLC-operating modes can be addressed by entering the code number **807 667**.

The following menu is displayed on the VDU:

**ERASE PLC PROGRAM**  
**PROGRAM FROM EPROM TRANSFER**  
**PLC EDITING MODE**  
**PLC PROGRAM TRACE MODE**  
**TABLES I/O/C/T/M**  
**TRANSLATE PLC PROGRAM**

The required mode is selected with the cursor keys ↑ and ↓ and activated by pressing ENT. The function is terminated by pressing NO ENT.

The menu can be exited by pressing END and a return is automatically made to the original NC-operating mode.

## Operating modes

## Deleting a program

In the operating mode **ERASE PLC PROGRAM**, a PLC-program contained in the RAM can be deleted by pressing the ENT-key. The RAM-memory is then cleared for a new program.

---

## Operating modes

## Transfer of program from EPROM

In the operating mode **TRANSFER PROGRAM FROM EPROM**, a program which is stored within the EPROM can be copied into the RAM-memory by pressing the ENT-key. The program can then be checked and edited via the operating mode **PLC EDITING MODE** (refer also to MP 4010).

In the operating mode **PLC EDITING MODE** an instruction list can be compiled or edited.

After pressing ENT, the editor identifies itself with

```
„0      EM“
```

„0“ stands for program line 0 and „EM“ for end of module.

When inserting an instruction, the character "EM" is automatically shifted downwards by one line.

With TNC 246 the keyboard is double assigned enabling an instruction list to be compiled using the keyboard overlay.  
With TNC 411/415 the instruction list is compiled via the ASCII-keyboard.

The "PLC-EDITIER-FUNKTION" can be exited by pressing the END-key.

**A complete instruction list comprises:**

- .Line numbers 0 to 6000
- .Command from command store (see description of Commands)
- .Operand type
- .Operand number
- .Remark

The **line number** is automatically generated on entering a command.

The **command, operand type, operand number** and the **remark** must be transferred via the ENT-key.

By doing this, the cursor jumps to the next position within the instruction. The instruction is completed after entry of the remarks.  
If no remark is to be entered, the position is simply finalised with ENT.

Lines which are to contain a **remark only** should be commenced with the character ";" instead of a command.

A remark can therefore cover several lines if each line commences with ";". A line contains a maximum of 26 characters for the remark and may include all numerals, alpha-characters and special characters which are available on the keyboard.

Keyboard layout for PLC-Editor (TNC 246)

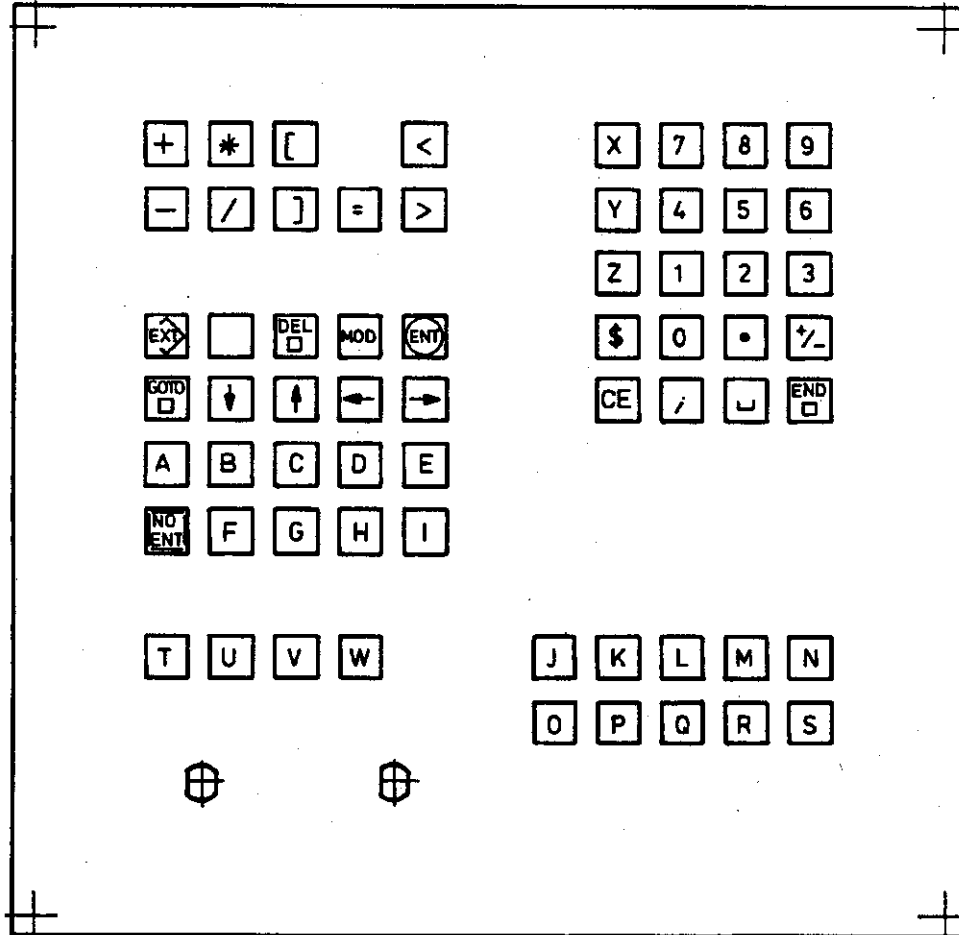

The operating mode **PLC PROGRAM TRACE** permits the checking of the logical status of markers, inputs, outputs, timers and counters.

If this function is addressed and called-up via ENT, the following **sub-menu** is displayed:

**SELECT I/O/C/T/M**  
**DISPLAY TRACE BUFFER**  
**START TRACE**  
**END TRACE**

## SELECT I/O/C/T/M

Those inputs (I), outputs (O), counters (C), timers (T) or markers (M) which are to be checked as to their logical state, can be entered into a table in the function **„SELECT I/O/C/T/M“**.

A maximum of 16 markers, timers etc. can be simultaneously verified. Each position is interrogated via dialogue. Erroneous entries can be deleted by pressing the DEL-key

Within the memory for the TRACE-mode (TRACE BUFFER) there is space for 1024 individual states per operand, i.e. 1024 PLC-processes are recorded.

In order to record the required time duration of the user, a TRIGGER-condition can be entered for each operand:

„1“ ⇒ Recording when operand is logic "1"

„0“ ⇒ Recording when operand is logic "0"

If the position "TRIGGER" is verified with the NO-ENT-key, it means that a TRIGGER condition is not required.

Before and after TRIGGER, 512 states are recorded. The TRIGGER is only regarded as fulfilled when the conditions for all operands are simultaneously fulfilled:

**Example:**

M2064	1
M2065	0
M2066	1
I5	
TRIGGER event:	M2064 logic "1"
	M2065 logic "0"
	M2066 logic "1"

The state of I5 has no significance for the TRIGGER event: it is however, recorded.

If no TRIGGER-condition is entered for the operands, the states of the operands are continually recorded and, after ending the TRACE-mode, the last 1024 states are displayed.

The mode "SELECT I/O/C/T/M" can be **exited** via the END-key.

## START TRACE

With this mode TRACE is started. Until the TRIGGER event occurs, the display **"PC TR"** flashes in the status field. TRACE can be terminated via the mode END-TRACE.

## END TRACE

If the TRIGGER (TRACE end) event is not performed, TRACE can be terminated by the function END TRACE. In this case, the last 1024 states of the selected operands are displayed.

## DISPLAY TRACE BUFFER

With the **DISPLAY TRACE BUFFER**-mode the logic states 0 or 1 of the selected operands are graphically displayed by a diagram. With simultaneous triggering the counter is reset to 0 (upper left in VDU). By using the cursor keys ← and → 512 logic states can be observed before and after the trigger event.

By this, it can be e.g. determined whether a marker, output etc. is reset either too early or too late. Taking the PLC-processing time of 24 ms into account, a time displacement in ms can be detected.

If, in the mode **SELECT I/O/C/T/M** a TRIGGER condition was not allocated for any of the operands (NO ENT), the states of the selected operands are dynamically displayed consecutively. After termination of the TRACE-function with TRACE BEENDEN, the last 1024 states are displayed.

---

# Operating modes

# Tables I/O/C/T/M

In the operating mode **TABLES I/O/C/T/M** the state of the inputs (I), outputs (O), counters (C), timers (T) and markers (M) can be dynamically displayed on the VDU. If, by means of the cursor keys, the required operand number is highlighted, this can be altered via Set (S) or Reset (R). The individual tables for inputs, outputs etc. are addressed via the ENT-key or the appropriate letter.

# Operating modes

# Program translation

A PLC-program which has been compiled using the PLC-editor and which is stored within the RAM must, prior to the test in the operating mode **"TRANSLATE PLC PROGRAM"**, be translated into a form which is can be understood by the microprocessor.

The translation procedure is commenced with the ENT-key.

A PLC-program which is already contained within the RAM prior to TNC-switch-on, need not be translated.

---

# Operating modes

# Utilization

In the operating mode **UTILIZATON** the used PLC-processing time and the vacant PLC-memory is displayed.

Data transmission can be activated via the EXT-key either from the main menu or in the PLC-editing function.

The following menu is displayed:

**READ -IN SELECTED PROGRAM**  
**OUTPUT ASCII**  
**OUTPUT ASCII UNFORMATTED**  
**OUTPUT ASCII WITH CROSS-REFERENCES**  
**BINARY OUTPUT**

PLC-programs compiled on an external computer can be read into the PLC-RAM either in the ME-mode or in the FE-mode via the RS-232-C/V.24 interface. Select "READ-IN SELECTED PROGRAM" and activate with ENT-key.





## Operand overview

M (Marker)	0 - 3279
I (Input)	I0 - I31; I128 - I151
O (Output)	O0 - O30
C (Counter)	C0 - C32
T (Timer)	T0 - T48
B (Byte)	0 - 1023 (8 Bit)
W (Word)	0 - 1022 (16 Bit)
D (Doubleword)	0 - 1020 (32 Bit)
K (Constant)	- 2 147 483 647 bis + 2 147 483 647

The memory for operands B, W, D, has a width of 8 bits. Since the operands have a width of 8, 16 or 32 bits an overlap of the memory range takes place and this should be taken into account for the addressing (see fig. 1).

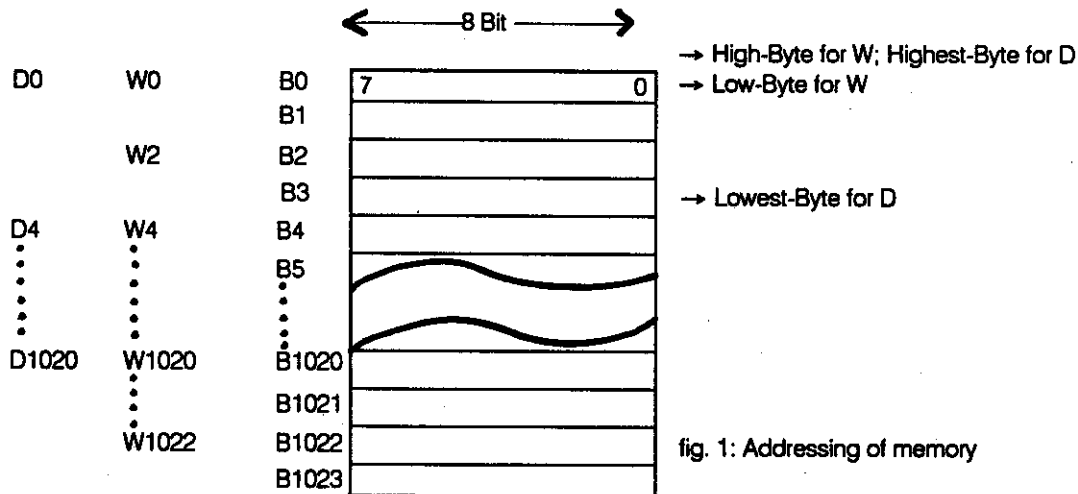

fig. 1: Addressing of memory

With Byte-addressing, each address from 0 - 1023 of the word processing memory can be accessed; with word-addressing every second 0 - 1022 and with doubleword - addressing every fourth 0 - 1020 (see section: "Assignment of word processing memory")

The address (W) and the highest Byte for the word address (W) and the highest Byte for the doubleword address (D). These therefore are the higher eated bits of the operand.

Example:

D204 (Highest-Byte)	=	W204 (High-Byte)	=	B204
-		W204 (Low-Byte)	=	B205
-		W206 (High-Byte)	=	B206
D204 (Lowest-Byte) =		W206 (Low-Byte)	=	B207

## Structure of PLC-processor

The following memories are available:

- Memory for the PLC-inputs  
Before a PLC-program is executed, the logic state of the PLC-inputs is read into this memory and remains unchanged until a PLC-program sequence (every 24 ms) is completed. Only at the beginning of the next sequence is this memory updated.
- Memory for the PLC-outputs  
In this memory the logic states of the PLC-outputs simultaneous to their calculation during a PLC-program sequence. They are transmitted to the hardware outputs of the PLC only at the end of a PLC-program. Outputs can therefore always change at the end of the sequence.
- Memory for markers  
Markers allocate 1 bit memories and serve in the intermediate storage of binary results. They can be set or reset during a PLC-program sequence and be interrogated with regard to their logic status.  
A distinction is made between user-markers, which the programmer can modify at random and permanently assigned markers which can only be set or reset by the NC or PLC. The latter forms the interface between the NC and the PLC and serves as a data exchange between both subassemblies.
- Memory for timers  
In this memory, timer markers are stored and updated in accordance with the PLC-program. Timer values are defined in the machine parameters.
- Memory for counters  
In this memory, counter markers are stored and updated in accordance with the PLC-program. Counter values are defined in the machine parameters.
- 8 bit organised memory for word-processing  
In this memory 8, 16, 32 bit wide data can be intermediately stored and called-up. The memory provides 1024 Bytes for this (see page P2/2).  
16 bit organised memory for data stack or storage of intermediate results.  
Addressing, as with the word-processing memory, is not possible.  
**The rule applies that the value which was entered into the stack last is first to be read again ("Last in – First out")**  
The stackpointer stipulates the sequence.
- 16 bit organised memory for program stack  
In this memory the return jump addresses for jump commands and module call-up as well as the contents of the logic and word accumulator for bracket statement are stored. The programmer does not have direct access to the storage addresses of the data and program stack. As with the data stack, the regulation of "last in – first out" applies.
- Logic accumulator  
The logic accumulator is a 1 bit register in which binary values and intermediately stored. A large part of the possible operations are executed via this logic accumulator.
- Word accumulator  
The word accumulator is a 32 bit register in which 32 bit wide data are intermediately stored.  
Nearly all operations require the "word accumulator" for storage of the results.
- Instruction pointer  
This determines the sequence of operations to be executed. It is only background – effective and is inaccessible to the programmer.

## Block diagram

The block diagram indicates which operations and which memory contents are linked together. The arrow direction defines the store in which the result is allocated.

The storage areas for program stack, data stack and command counters cannot be addressed by the programmer directly.

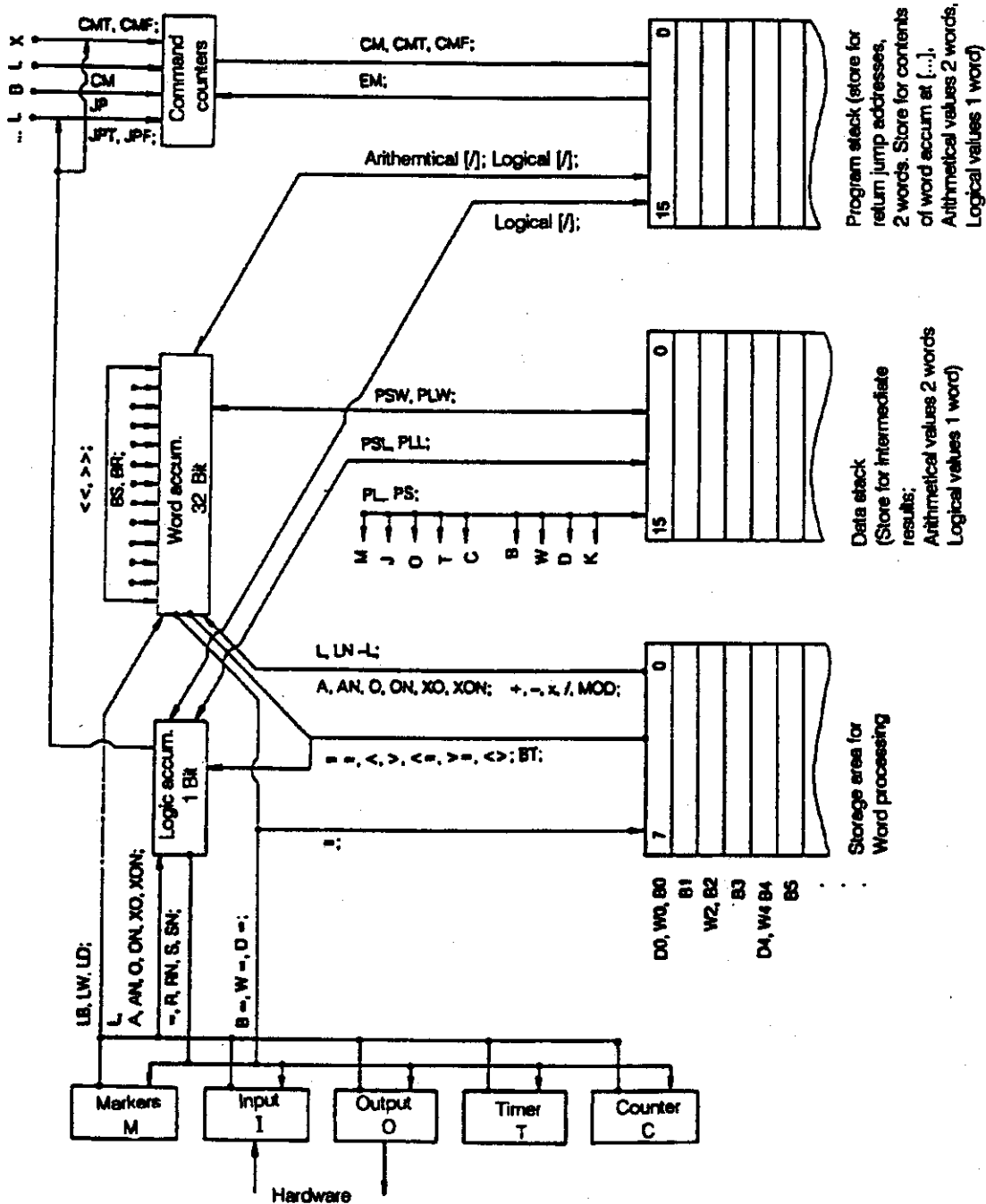

## Logic gates

Command	Abbr. for PLC-editor	Operands	Remarks
AND	A	M, I, O, T, C	The logic gates with the operands M, I, O, T, C effect a gating of the operand bit with the contents of the <b>logic accu</b> .
NAND	AN		At the beginning of the logic sequence these commands act as load commands, i.e. the addressed operand is loaded in the <b>logic accu</b> . The gating result is located in the <b>logic accu</b> .
OR	O	B, W, D, K	The logic gates with the operands B, W, D, K effect a gating of the operand contents with the contents of the <b>word accu</b> .
NOR	ON		Depending on the operand, 8, 16 or 32 bits of the word accu. can be influenced.
Exklusiv-OR	XO		The gating result is located in the word accu.
Exklusiv-NOR	XON		The open bracket command internally stores the contents of the logic accu. and the word accu. within the program stack.
Logic open bracket	A [ AN [ O [ ON [ XO [ XON [ ]	none	If, in the last command, prior to the open bracket command, the logic accu is addressed, the contents of the logic accu. are stored. If, in the last command, prior to the open bracket command, the word accu. is addressed, the contents of the word accu. are stored. This open bracket instruction is used in conjunction with the logical commands A, AN, O, ON, XO, XON thus resulting in commands A[, AN[, O[, ON[, XO[, XON[.
Logic close bracket	]	none	The close bracket instruction effects a gating of the intermediately stored value from the program stack with the logic or word accu. This depends on which accu. was addressed prior to the open bracket instruction. The result is then available in the appropriate accumulator.

## Arithmetical functions

Command	Abbr. for PLC-editor	Operands	Remarks
Arithmetical commands			
Plus	+	B W D K	With the arithmetical functions, the operand is character-extended by 32 bits and gated with the word accu. in accordance with the command. The result is stored in the word accu.
Minus	-		With erroneous execution: marker 3264 is set for multiplication marker 3265 for division and marker 32 66 for MOD, otherwise it is reset.
Multiplication	x	B W K	
Division	/		
Division remainder	MOD	B W K	With TNC 2500 the following limitations apply: For multiplication, division and modulo-functions doublewords are not permitted. With multiplication only the first 16 bits of the word accumulator are computed.
Arithmetical open bracket	[	none	Due to the open bracket command, the contents of the word accumulator are intermediately stored within the program stack. The open bracket command is used in conjunction with the arithmetical commands +, -, x / and MOD, thus resulting in the commands +[, -[, x[, /[, MOD[.
Arithmetical close bracket	]	none	With TNC 246 the following limitations apply: + [ and - [ perform a 32 bit operation x [ performs < 16 bit x 16 bit = 32 bit operation / [ and MOD [ performs a 32 bit/16 bit = 16 bit operation  The close bracket instruction effects a gating between intermediately stored values within the program stack and the word accu.  The result is stored in the word accu.

## Logic comparisons

Command	Abbr. for PLC-editor	Operands	Remarks
Logic comparisons			
Equal to	=	B, W, D, K	With logical comparisons, the contents of the operand within a width of 8, 16 or 32 bits (depending on the operand type) is compared with the contents of the word accumulator.
Less than	<	B, W, D, K	If the condition of the comparison is fulfilled, the logic accumulator is set or otherwise deleted.
Greater than	>	B, W, D, K	
Less than or equal to	<=	B, W, D, K	With the open bracket command, the contents of the word accumulator are intermediately stored in the program stack. This releases the word accumulator for the computing of the bracket contents. The total 32 bit word accumulator is always compared with the intermediately stored value. If the condition of the comparison is fulfilled, the logic accumulator is set or otherwise deleted.
Greater than or equal to	>=	B, W, D, K	
Unequal	<>	B, W, D, K	The close bracket instruction performs the comparison and sets the logic accumulator by means of the comparison result.
Logic comparison of a bracketed statement	= [	none	
	< [		
	> [		
	<= [		
	>= [		
	<> [		
Close bracket	]		

## Shift functions

Command	Abbr. for PLC-editor	Operands	Remarks
Shift left	<<	B, W, D, K	The shift instruction initiates a shift of the contents of the word accumulator (32 bits) either left or right by the number of bits defined in the operand.
Shift right	>>	B, W, D, K	With operand contents exceeding 32, the operand value Modulo 32 is used, i.e. the contents are reduced by 32.

## Bit manipulation

Command	Abbr. for PLC-editor	Operands	Remarks
Bit set	BS	B, W, D, K	In the word accumulator the bit addressed through the contents of the contents of the operand is set with BS and reset with BR.
Bit reset	BR		For operand contents exceeding 32, the operand contents Modulo 32 applies. For bit numbering of the word accumulator: Bit 0 = LSB and Bit 31 = MSB.
Bit test	BT	B, W, D, K	In the word accumulator, the bit addressed through the contents of the operand is compared with the logic accumulator. The logic accumulator is set in accordance with the result.
			For operand contents exceeding 32, the operand contents Modulo 32 applies.



## Load commands

Command	Abbr. for PLC-editor	Operands	Remarks
Load	L	M, I, O, T, C	The load commands (L, LN) in conjunction with the operands M, I, O, T, C effects the loading of the logic accumulator. At the beginning of a logic gating sequence, this function can also be achieved with the logic gating commands (A, AN).
Load Single complement	LN	M, I, O, T, C	
Load	L	B, W, D, K	Th load commands L, LN, L- in conjunction with the operands B, W, D, K effect the loading of the word accumulator which is extended to 32 bits arithmetical sign. At the beginning of a word gating sequence, this command <b>must</b> be used!
Load Single complement	LN	B, W, D, K	
Load Double complement	L-	B, W, D, K	With these load instructions and depending on the command (LB, LW, LD), 8, 16 or 32 markers, inputs, outputs, timers or counters are combined into a Byte, word or doubleword in ascending numbers and stored in the word accumulator.  The M, I, O, T or C with the operand parameter will be the LSB and the last M, I, O, T or C the MSB. If required, the result is extended by the sign.
Load Byte	LB	M, I, O, T, C	
Load word	LW	M, I, O, T, C	
Load doubleword	LD	M, I, O, T, C	

## Assignments

Command	Abbr. for PLC-editor	Operands	Remarks
Assignment of a Byte from word accumulator	B =	M, I, O, T, C	With these assignments and depending on the command (B=, W=, D=), 8, 16 or 32 markers, input, output, timer or counter are assigned in ascending order of number, with the contents of the word accumulator which are broken down bit-wise.
Assignment of a word from word accumulator	W =	M, I, O, T, C	The LSB of the word accumulator is assigned to the M, I, O, T or C with the operand parameter; the MSB of the word accumulator to the last M, I, O, T or C.
Assignment of a doubleword from word accumulator	D =	M, I, O, T, C	
Assignment	=	M, E, A, T, Z	With an assignment, the contents of the logic accumulator are assigned to a marker, input, output, timer or counter.
Assignment	=	B, W, D	With this assignment the contents of the word accumulator are assigned to a B, W or D.

## Set-commands

Command	Abbr. for PLC-editor	Operands	Remarks
Set when logic accu. is = 1	S	M, I, O, T, C	When the logic accumulator is = 1, the addressed operand M, I, O, T or C is set. Otherwise the operand remains unchanged.
Reset when logic accu. is = 1 (Set not)	R	M, I, O, T, C	When the logic accumulator is = 1, the addressed operand M, I, O, T or C is reset. Otherwise it remains unchanged.
Set when logic accu. is = 0 (Reset not)	SN	M, I, O, T, C	When the logic accumulator is = 0, the addressed operand M, I, O, T, or C is set. Otherwise it remains unchanged.
Reset when logic accu. is = 0	RN	M, I, O, T, C	When the logic accumulator is = 0, the addressed operand M, I, O, T, or C is reset. Otherwise it remains unchanged.

## Jump commands

Command	Abbr. for PLC-editor	Operands	Remarks
Unconditional Jump	JP	Label (LBL)	Due to the jump command, the program is continued from the defined label
(Jump true) Jump when logic accu. = 1	JPT	Label (LBL)	The jump command (JPT) is only executed when the logic accu. is 1.
(Jump false) Jump when logic a accu. = 0	JPF	Label (LBL)	The jump command (JPF) is only executed when the logic accu. is 0.
Call module	CM	Label (LBL)	With call-up of the module (CM) program execution is continued with the modules marked by the label.  The contents of the logic accumulator are intermediately stored in the program stack and are available again after the CM-command.
(Call module true) Module call when logic accu. = 1	CMT	Label (LBL)	The module call (CMT) is only performed when the logic accu. = 1.
(Call module false) Module call when logic accu. = 0	CMF	Label (LBL)	The module call (CM) is only performed when the logic accu. = 0.
End of module End of program	EM		Every module and every program is completed with an EM-instruction. End of module initiates a program continuation at the program location which follows a CM, CMT or CMF-instruction.
Case Module call	CASE	B, W	The command EM is dealt with as per a program end criterion. Therefore subsequent program instructions can be reached via a jump label.  With the CASE-instruction and the related operand B or W, a subsequent CM-instruction can be indicated.  This CM-instruction max. 32 directly follows the CASE-instruction and are numbered in ascending sequence from 0 to max. 31.

Command	Abbr. for PLC-editor	Operands	Remarks
(End case) End of module call	ENDC	-	The contents of the operand addresses the corresponding CM-instructions to be executed.  The CM-instructions must directly follow an ENDC.
Jump label	LBL	(0 - 511)	The label defines a program location as jump-in access for CM and JP-commands. Labels can given the addresses from 0 to 511. The LBL-command erases the program end criterion (EM), since at this point, a jump into the program can be made with LBL.

## Stack operations

Command	Abbr. for PLC-editor	Operands	Remarks																																																		
(Push stack) Loading of data onto data stack	PS	M, I, O, T, C  B, W, D, K	The instruction PS loads the addressed M, I, O, T or C onto bit 7 of a free word of the data stack. The free bits of this word are unused.  <div style="text-align: center;"> <pre>           15 7 0            ---            XXXXXX L XXXXXX           </pre> </div> <p>The instruction PS loads the addressed B, W, D or K into the words of the data stack. The free bits are defined as a sign and then correspond to bit 7 or bit 15</p> <table style="margin-left: auto; margin-right: auto;"> <tr> <td>XXXXXX</td><td>XXXXXX</td><td>XXXXXX</td><td>XXXXXX</td><td>XXXXXX</td><td>XXXXXX</td><td>XXXXXX</td><td>XXXXXX</td><td>XXXXXX</td><td>XXXXXX</td> </tr> <tr> <td>XXXXXX</td><td>XXXXXX</td><td>XXXXXX</td><td>XXXXXX</td><td>XXXXXX</td><td>XXXXXX</td><td>XXXXXX</td><td>XXXXXX</td><td>XXXXXX</td><td>XXXXXX</td> </tr> <tr> <td>DDDDDD</td><td>DDDDDD</td><td>DDDDDD</td><td>DDDDDD</td><td>DDDDDD</td><td>DDDDDD</td><td>DDDDDD</td><td>DDDDDD</td><td>DDDDDD</td><td>DDDDDD</td> </tr> <tr> <td>KKKKKK</td><td>KKKKKK</td><td>KKKKKK</td><td>KKKKKK</td><td>KKKKKK</td><td>KKKKKK</td><td>KKKKKK</td><td>KKKKKK</td><td>KKKKKK</td><td>KKKKKK</td> </tr> <tr> <td style="text-align: center;">31</td><td style="text-align: center;">15</td><td style="text-align: center;">7</td><td style="text-align: center;">0</td><td></td><td></td><td></td><td></td><td></td><td style="text-align: center;">0</td> </tr> </table> <p>Stack overflow is output as an error message!</p>	XXXXXX	XXXXXX	XXXXXX	XXXXXX	XXXXXX	XXXXXX	XXXXXX	XXXXXX	XXXXXX	XXXXXX	XXXXXX	XXXXXX	XXXXXX	XXXXXX	XXXXXX	XXXXXX	XXXXXX	XXXXXX	XXXXXX	XXXXXX	DDDDDD	DDDDDD	DDDDDD	DDDDDD	DDDDDD	DDDDDD	DDDDDD	DDDDDD	DDDDDD	DDDDDD	KKKKKK	KKKKKK	KKKKKK	KKKKKK	KKKKKK	KKKKKK	KKKKKK	KKKKKK	KKKKKK	KKKKKK	31	15	7	0						0
XXXXXX	XXXXXX	XXXXXX	XXXXXX	XXXXXX	XXXXXX	XXXXXX	XXXXXX	XXXXXX	XXXXXX																																												
XXXXXX	XXXXXX	XXXXXX	XXXXXX	XXXXXX	XXXXXX	XXXXXX	XXXXXX	XXXXXX	XXXXXX																																												
DDDDDD	DDDDDD	DDDDDD	DDDDDD	DDDDDD	DDDDDD	DDDDDD	DDDDDD	DDDDDD	DDDDDD																																												
KKKKKK	KKKKKK	KKKKKK	KKKKKK	KKKKKK	KKKKKK	KKKKKK	KKKKKK	KKKKKK	KKKKKK																																												
31	15	7	0						0																																												

Command	Abbr. for PLC-editor	Operands	Remarks
(Push stack) Acquire data from stack	PL	M, I, O, T, C  B, W, D, K	<p>The instruction PL collects the 7<sup>th</sup> bit from the current address of the stack and transfers it to the addressed operand.</p> <p>The instruction PL loads the current word or doubleword of the stack into the addressed operand.</p> <p>It is checked as to whether the stack is empty; if yes an error message is output.</p>
(Push Logic accu.) Load logic accum. onto data stack	PSL	-	<p>The instruction PSL loads the contents of the logic accu. onto the stack. As with the command PS, the 7<sup>th</sup> bit is addressed to the current word of the stack.</p> <p>The instruction checks for stack overflow. If yes, an error message is output.</p>
(Push word accu.) Load word accum. onto data stack	PSW	-	<p>The instruction PSW loads the contents of the word accu. onto the stack. It is checked if the stack is at overflow, if yes, an error message is output.</p>
(Push word accu.) Load word accum. from stack	PLW	-	<p>The instruction PLW loads the contents, of the current word (doubleword) of the stack into the word accumulator.</p> <p>It is checked as to whether the stack is empty; if yes an error message is output.</p>
(Pull Logic accu.) Load logic accum. from stack	PLL	-	<p>The instruction PLL loads the 7<sup>th</sup> bit of the current word of the stack into the logic accumulator. It is checked as to whether the stack is empty; if yes, an error message is output.</p>

The PLC-EPROM is a 1 MB chip with 16 bit data organisation. Programming is in Motorola format, i.e. the highest valued Byte of a word is located at the first (lowest valued) address.

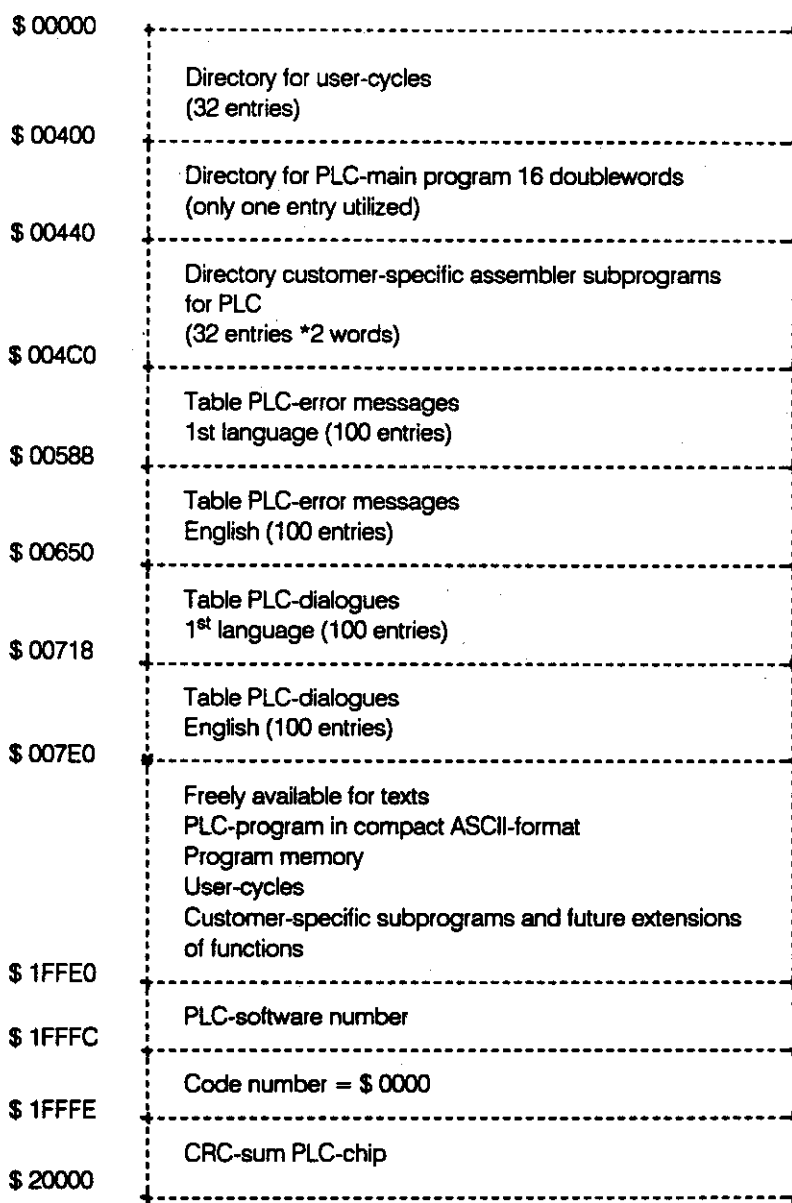

## TNC 2500

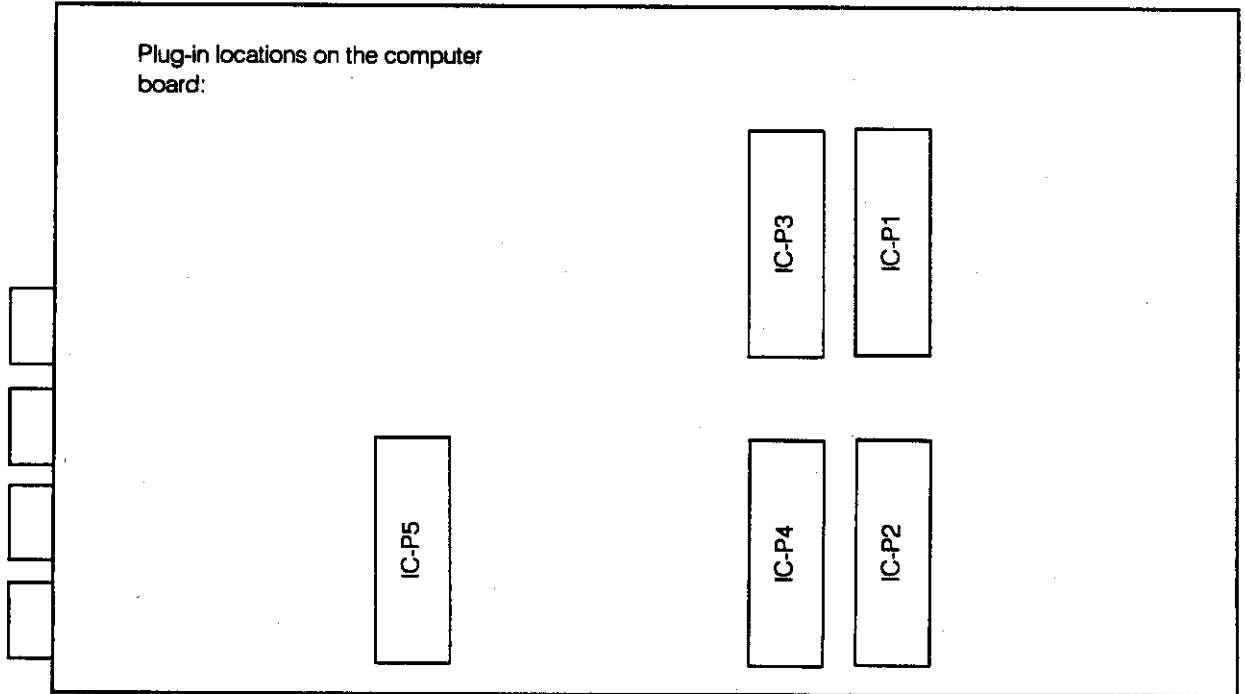

Defined memory sections form the interface between NC and PLC. Two memory sections are available:

- Memory section for markers
- Memory section for words

**Markers 2719:** Switchover of strobe

With marker 2719 the subsequent markers can be allocated to the memory section for markers (as per TNC 355) or the memory section for words.

M2719: 0 → strobos in memory section for markers  
1 → strobos in memory section for words

When M2719 = 1, the data of the appropriate function are also stored in the word-processor memory.

**Switchable strobos:**

Markers	Meaning	Data if M2719 = 1
M2704	Start PC-Pos X	D528
M2705	Start PC-Pos Y	D532
M2706	Start PC-Pos Z	D536
M2707	Start PC-Pos IV	D540
M2712	Start spindle orient.	D592
M2713	Strobe Write Q-Par	D5287/Q-Number: W516
M2714	StrobeWrite Tool	W512/W514
M2715	Strobe Read Tool	W512/W564
M2716	Strobe datum correction	D528-D556



Marker No.	Function
2000	Enable axis X
2001	Enable axis Y
2002	Enable axis Z
2003	Enable axis IV
2004	"0" = analogue voltage for spindle drive is located in ramp
2005	"1" = analogue voltage for spindle drive is 0 V
2008	X-axis in position
2009	Y-axis in position
2010	Z-axis in position
2011	IV-axis in position
2012	Lubrication pulse necessary, X-axis limit exceeded
2013	Lubrication pulse necessary, Y-axis limit exceeded
2014	Lubrication pulse necessary, Z-axis limit exceeded
2015	Lubrication pulse necessary, IV-axis limit exceeded
2020	rpm nominal < rpm min. of MP
2022	Probe system not ready
2023	Stylus already deflected at start of probing cycle
2024	Probing system ready (TS 511)
2025	Stylus deflected. Probing procedure completed
2026	Probing procedure completed
2027	Battery voltage tool low (TS 511)
2032	1. Bit T-Code (lsb)
2033	2. Bit T-Code
2034	3. Bit T-Code
2035	4. Bit T-Code
2036	5. Bit T-Code
2037	6. Bit T-Code
2038	7. Bit T-Code
2039	8. Bit T-Code (msb)
2041	English dialogue language is selected
2042	Control operates with S-analogue
2043	Change signal G-Code for S-analogue
2044	Change signal S-Code
2045	Change signal M-Code
2046	Change signal T-Code
2047	Change signal 2 <sup>nd</sup> T-Code

Marker No.	Function
2048	Tapping cycle is called
2049	Background editing mode
2050	Programming
2051	Manual operation
2052	Electronic handwheel
2053	Positioning with MDI
2054	Program run signal block
2055	Program run full sequence
2056	Program test
2057	Approach to reference point
2060	Marker for DIN/ISO programming
2061	Marker showing activation of END-PGM, M02, M30
2064	1. Bit S-Code (lsb)
2065	2. Bit S-Code
2066	3. Bit S-Code
2067	4. Bit S-Code
2068	5. Bit S-Code
2069	6. Bit S-Code
2070	7. Bit S-Code
2071	8. Bit S-Code (msb)
2072	1. Bit M-Code (lsb)
2073	2. Bit M-Code
2074	3. Bit M-Code
2075	4. Bit M-Code
2076	5. Bit M-Code
2077	6. Bit M-Code
2078	7. Bit M-Code
2079	8. Bit M-Code (msb)
2080	1. Bit for minimum (lsb)
2081	2. Bit for minimum
2082	3. Bit for minimum
2083	4. Bit for minimum
2084	5. Bit for minimum
2085	6. Bit for minimum
2086	7. Bit for minimum
2087	8. Bit for minimum (msb)

Marker No.	Function
2088	1. Bit for step width (lsb)
2089	2. Bit for step width
2090	3. Bit for step width
2091	4. Bit for step width (msb)
2092	Marker for display "wrong rpm"
2093	Toolchange of special to normal tool
2096	Currently activated TNC axis key X
2097	Currently activated TNC axis key Y
2098	Currently activated TNC axis key Z
2099	Currently activated TNC axis key IV
2100	X-axis is tool axis
2101	Y-axis is tool axis
2102	Z-axis is tool axis
2103	IV-axis is tool axis
2104	1. Bit gear change Code S-Analogue (lsb)
2105	2. Bit gear change Code S-Analogue
2106	3. Bit gear change Code S-Analogue (msb)
2112	Tool pocket number 1 <sup>st</sup> decade (lsb)
2113	Tool pocket number 1 <sup>st</sup> decade
2114	Tool pocket number 1 <sup>st</sup> decade
2115	Tool pocket number 1 <sup>st</sup> decade (msb)
2116	Tool pocket number 2 <sup>nd</sup> decade (lsb)
2117	Tool pocket number 2 <sup>nd</sup> decade
2118	Tool pocket number 2 <sup>nd</sup> decade
2119	Tool pocket number 2 <sup>nd</sup> decade (msb)
2128	Traversing of X-axis
2129	Traversing of Y-axis
2130	Traversing of Z-axis
2131	Traversing of IV-axis
2160	Traverse direction X-axis
2161	Traverse direction Y-axis
2162	Traverse direction Z-axis
2163	Traverse direction IV-axis
2176	Code operating mode (lsb)
2177	Code operating mode
2178	Code operating mode

Marker No.	Function
2179	Code operating mode (msb) 0000 = Programming 0001 = Manual operation 0010 = Electronic handwheel 0011 = Positioning with MDI 0100 = Program run single block 0101 = Program run full sequence
2180	1 <sup>st</sup> PLC-cycle run after power on
2182	Inhibited TNC-key pressed
2183	Program interruption (flashing of operation display lamp)
2184	Control in operation (permanent operation pilot)
2185	1 <sup>st</sup> PLC-cycle run after interruption of PLC-program
2190	Erasable error display is displayed
2191	Error "external emergency stop" is displayed
	Markers influenced by machine parameter 4310.0
2192	(Significance 1)
2193	(Significance 2)
2194	(Significance 4)
2195	(Significance 8)
2196	(Significance 16)
2197	(Significance 32)
2198	(Significance 64)
2199	(Significance 128)
2200	(Significance 256)
2201	(Significance 512)
2202	(Significance 1024)
2203	(Significance 2048)
2204	(Significance 4096)
2205	(Significance 8192)
2206	(Significance 16 384)
2207	(Significance 32 768)
	Markers affected by machine parameter 4310.1
2208	(Significance 1)
2209	(Significance 2)
2210	(Value 4)
2211	(Value 8)
2212	(Value 16)
2213	(Value 32)
2214	(Value 64)

Marker No.	Function
2215	(Significance 128)
2216	(Significance 256)
2217	(Significance 512)
2218	(Significance 1024)
2219	(Significance 2048)
2220	(Significance 4096)
2221	(Significance .92)
2222	(Significance 16 384)
2223	(Significance 32 768)
2224	Markers affected by machine parameter 4310.2 (Significance 1)
2225	(Significance 2)
2226	(Significance 4)
2227	(Significance 8)
2228	(Significance 16)
2229	(Significance 32)
2230	(Significance 64)
2231	(Significance 128)
2232	(Significance 256)
2233	(Significance 512)
2234	(Significance 1024)
2235	(Significance 2048)
2236	(Significance 4096)
2237	(Significance 8192)
2238	(Significance 16 384)
2239	(Significance 32 768)
2240	User-cycle 68
2241	User-cycle 69
2242	User-cycle 70
2243	User-cycle 71
2244	User-cycle 72
2245	User-cycle 73
2246	User-cycle 74
2247	User-cycle 75
2248	User-cycle 76
2249	User-cycle 77
2250	User-cycle 78
2251	User-cycle 79



Marker No.	Function
2400	Tool No. 0 programmed
2401	New tool with location No. aktiv during T-strobe
2402	New tool without location No. aktiv during T-strobe
2448	NC-start
2449	NC-rapid
2450	Memory function for manual traversing
2451	Feed release
2452	Start PLC-positioning X-axis
2453	Start PLC-positioning Y-axis
2454	Start PLC-positioning Z-axis
2455	Start PLC-positioning IV-axis
2456	Manual traversing X+
2457	Manual traversing X-
2458	Manual traversing Y+
2459	Manual traversing Y-
2460	Manual traversing Z+
2461	Manual traversing Z-
2462	Manual traversing IV+
2463	Manual traversing IV-
2464	Complemented NC-start
2465	Complemented NC-rapid
2466	Complemented memory function for manual traversing
2467	Complemented feed release
2468	Complemented start PLC-positioning X-axis
2469	Complemented start PLC-positioning Y-axis
2470	Complemented start PLC-positioning Z-axis
2471	Complemented start PLC-positioning IV-axis
2472	Complemented manual traverse X+
2473	Complemented manual traverse X-
2474	Complemented manual traverse Y+
2475	Complemented manual traverse Y-
2476	Complemented manual traverse Z+
2477	Complemented manual traverse Z-
2478	Complemented manual traverse IV+
2479	Complemented manual traverse IV-
2480	Feedback signal gear change code S-Analogue
2481	Feedback S-Code
2482	Feedback M-Code























































Marker No.	Function	
2601	Marker for location of special tool	
2608	Display status M03; M04, M05 inverse and S-analog = 0 V	
2609	Display status M08/M09 inverse	
2624	Limit Switch X+	
2625	Limit Switch X-	
2626	Limit Switch Y+	
2627	Limit Switch Y-	
2628	Limit Switch Z+	
2629	Limit Switch Z-	
2630	Limit Switch IV+	
2631	Limit Switch IV-	
2656	Spindle orientation from standstill	
2688	No supervision on X-axis	
2689	No supervision on Y-axis	
2690	No supervision on Z-axis	
2691	No supervision on IV-axis	
2704	Strobe PLC-Positioning Axis X	Data: D 528
2705	Strobe PLC-Positioning Axis Y	Data: D 532
2706	Strobe PLC-Positioning Axis Z	Data: D 536
2707	Strobe PLC-Positioning Axis IV	Data: D 540
2713	Strobe Q-parameter read out	Data: D 528 Q-Number: W 516
2714	Strobe tool No. to read out	Data: D 512 / W 514
2715	Strobe to read tool No.	Data: D 512 / W 264
2716	Strobe for datum shift	Data: D 528 – D 556
2719	Selection of data and strobes from Word memory or MP List (TNC 355)	
2800	TNC key code (lsb) for remote operation of TNC keys (for coding see markers 2855 – 2923)	
2801	TNC key code for remote operation of TNC keys (for coding see markers 2855 – 2923)	
2802	TNC key code for remote operation of TNC keys (for coding see markers 2855 – 2923)	
2803	TNC key code for remote operation of TNC keys (for coding see markers 2855 – 2923)	
2804	TNC key code for remote operation of TNC keys (for coding see markers 2855 – 2923)	
2805	TNC key code for remote operation of TNC keys (for coding see markers 2855 – 2923)	
2806	TNC key code for remote operation of TNC keys (for coding see markers 2855 – 2923)	
2807	TNC key code (msb) for remote operation of TNC keys (for coding see markers 2855 – 2923)	



Marker No.	Function	Key-Code		
		msb	lsb	
2855	 Inhibit	0011	1011	
2856	 Inhibit	0011	1100	
2857	 Inhibit	0011	1101	
2858	 Inhibit	0011	1110	
2859	 Inhibit	0011	1111	
2860	 Inhibit	0100	0000	
2861	 Inhibit	0100	0001	
2862	 Inhibit	0100	0010	
2863	 Inhibit	0100	0011	
2864	 Inhibit	0100	0100	
2865	 Inhibit	0100	0101	
2867	 Inhibit	0100	0111	
2868	 Inhibit	0100	1000	
2869	 Inhibit	0100	1001	
2870	 Inhibit	0100	1010	
2871	 Inhibit	0100	1011	
2872	 Inhibit	0100	1100	
2873	 Inhibit	0100	1101	
2874	 Inhibit	0100	1110	
2880	 Inhibit	0101	0100	
2881	 Inhibit	0101	0101	
2882	 Inhibit	0101	0110	
2883	 Inhibit	0101	0111	

Marker No.	Function	Key-Code		
		msb	lsb	
2884	 Inhibit	0101	1000	
2885	 Inhibit	0101	1001	
2886	 Inhibit	0101	1010	
2887	 Inhibit	0101	1011	
2888	 Inhibit	0101	1100	
2889	 Inhibit	0101	1101	
2890	 Inhibit	0101	1110	
2891	 Inhibit	0101	1111	
2892	 Inhibit	0110	0000	
2893	 Inhibit	0110	0001	
2894	 Inhibit	0110	0010	
2895	 Inhibit	0110	0011	
2896	 Inhibit	0110	0100	
2897	 Inhibit	0110	0101	
2898	 Inhibit	0110	0110	
2899	 Inhibit	0110	0111	
2900	 Inhibit	0110	1000	
2901	 Inhibit	0110	1001	
2902	 Inhibit	0110	1010	
2903	 Inhibit	0110	1011	
2904	 Inhibit	0110	1011	
2905	 Inhibit	0110	1101	
2906	 Inhibit	0110	1110	

Marker No.	Function	Key-Code		
		msb	lsb	
2907	<b>0</b> Inhibit	0110	1111	
2908	<b>1</b> Inhibit	0111	0000	
2909	<b>4</b> Inhibit	0111	0001	
2910	<b>7</b> Inhibit	0111	0010	
2911	<b>.</b> Inhibit	0111	0011	
2912	<b>2</b> Inhibit	0111	0100	
2913	<b>5</b> Inhibit	0111	0101	
2914	<b>8</b> Inhibit	0111	0110	
2915	<b>END</b> Inhibit	0111	0111	
2916	<b>MOD</b> Inhibit	0111	1000	
2917	<b>BLK FORM</b> Inhibit	0111	1001	
2918	<b>MAGN</b> Inhibit	0111	1010	
2919	<b>START</b> Inhibit	0111	1011	
2920	<b>+/-</b> Inhibit	0111	1100	
2921	<b>3</b> Inhibit	0111	1101	
2922	<b>6</b> Inhibit	0111	1110	
2923	<b>9</b> Inhibit	0111	1111	
2924	Error message 0			
2925	Error message 1			
2926	Error message 2			
2927	Error message 3			
2928	Error message 4			
2929	Error message 5			
2930	Error message 6			
2931	Error message 7			
2932	Error message 8			
2933	Error message 9			

Marker No.	Function
2934	Error message 10
2935	Error message 11
2936	Error message 12
2937	Error message 13
2938	Error message 14
2939	Error message 15
2940	Error message 16
2941	Error message 17
2942	Error message 18
2943	Error message 19
2944	Error message 20
2945	Error message 21
2946	Error message 22
2947	Error message 23
2948	Error message 24
2949	Error message 25
2950	Error message 26
2951	Error message 27
2952	Error message 28
2953	Error message 29
2954	Error message 30
2955	Error message 31
2956	Error message 32
2957	Error message 33
2958	Error message 34
2959	Error message 35
2960	Error message 36
2961	Error message 37
2962	Error message 38
2963	Error message 39
2964	Error message 40
2965	Error message 41
2966	Error message 42
2967	Error message 43
2968	Error message 44
2969	Error message 45
2970	Error message 46
2971	Error message 47
2972	Error message 48



Marker No.	Function
2973	Error message 49
2974	Error message 50
2975	Error message 51
2976	Error message 52
2977	Error message 53
2978	Error message 54
2979	Error message 55
2980	Error message 56
2981	Error message 57
2982	Error message 58
2983	Error message 59
2984	Error message 60
2985	Error message 61
2986	Error message 62
2987	Error message 63
2988	Error message 64
2989	Error message 65
2990	Error message 66
2991	Error message 67
2992	Error message 68
2993	Error message 69
2994	Error message 70
2995	Error message 71
2996	Error message 72
2997	Error message 73
2998	Error message 74
2999	Error message 75
3000	Error message 76
3001	Error message 77
3002	Error message 78
3003	Error message 79
3004	Error message 80
3005	Error message 81
3006	Error message 82
3007	Error message 83
3008	Error message 84 / User parameter 16
3009	Error message 85 / User parameter 15
3010	Error message 86 / User parameter 14
3011	Error message 87 / User parameter 13



# Permanently assigned memory Byte, Word, Doubleword

The memory can be accessed as a Byte, Word or Doubleword. Every second address is used for a word and every fourth for a doubleword.

B0 – B255	Freely available, <b>erased with reset.</b>
B256 – B511	Data transfer NC → PLC
B512 – B767	Data transfer PLC → NC
B768 – B1023	Machine parameters

## Data transfer NC → PLC

Address	Function
W256	G-Code with S-analogue (active with G-strobe M2043)
W258	S-Code (active with S-strobe M2044)
W260	M-Code (active with M-strobe M2045)
W262	T-Code (active with T-strobe M2046)
W264	P-Code (active with P-strobe M2598)
W272	Operating mode 0 = Edit 1 = Manual 2 = Handwheel 3 = Teach-in 4 = Program run single block 5 = Program run full sequence 6 = Program test
W274	Key code, inhibited keys
D288	actual position X
D292	actual position Y
D296	actual position Z
D300	actual position IV

# Permanently assigned memory Byte, Word, Doubleword

Address	Function
D324	nominal position X
D328	nominal position Y
D332	nominal position Z
D336	nominal position IV

## Data transfer PLC → NC

Address	Function
W512	T-code with read/write tool file (Strobe M2714)
W514	P-code with Write tool file (Strobe M2715)
W516	Q-number with Q-strobe M2713 (Q100 ... Q107), T-code with Strobe M2813

# Permanently assigned memory Byte, Word, Doubleword

## Multiple-use doublewords (Units 1 $\mu$ m)

Address	Function
D528	Position for PLC-Pos. X (Strobe M2704) Data at transfer (Strobe M2713) Datum shift of PLC X (Strobe 2716)
D532	Position for PLC-Pos. Y (Strobe M2705) Datum shift of PLC Y (Strobe M2716)
D536	Position for PLC-Pos. Z (Strobe M2706) Datum shift of PLC Z (Strobe M2716)
D540	Position for PLC-Pos. 4 (Strobe M2707) Datum shift of PLC IV (Strobe M2716)

## Multiple-use words (unit mm/min)

Address	Function
W560	Feed rate with PLC-Pos. X (Strobe M2704)
W562	Feed rate with PLC-Pos. Y (Strobe M2705)
W564	Feed rate with PLC-Pos. Z (Strobe M2706)
W566	Feed rate with PLC-Pos. IV (Strobe M2707)

Address	Function
W576	Datum correction of PLC X
W578	Datum correction of PLC Y
W580	Datum correction of PLC Z
W582	Datum correction of PLC IV

# Permanently assigned memory Byte, Word, Doubleword

## Machine parameters (NC → PLC)

MP 4210 doubleword incl. sign  
Meaning when M2719 = Ø  
0 – 31 positions PLC-positioning  
32 – 36 Datum correction 1  
37 – 41 Datum correction 2  
42 – 46 Datum correction 3

D768	MP	4210.0
D772	MP	4210.1
D776	MP	4210.2
D780	MP	4210.3
D784	MP	4210.4
D788	MP	4210.5
D792	MP	4210.6
D796	MP	4210.7
D800	MP	4210.8
D804	MP	4210.9
D808	MP	4210.10
D812	MP	4210.11
D816	MP	4210.12
D820	MP	4210.13
D824	MP	4210.14
D828	MP	4210.15
D832	MP	4210.16
D836	MP	4210.17
D840	MP	4210.18
D844	MP	4210.19
D848	MP	4210.20
D852	MP	4210.21
D856	MP	4210.22
D860	MP	4210.23
D864	MP	4210.24
D868	MP	4210.25
D872	MP	4210.26
D876	MP	4210.27
D880	MP	4210.28
D884	MP	4210.29
D888	MP	4210.30
D892	MP	4210.31
D896	MP	4210.32
D900	MP	4210.33
D904	MP	4210.34



# Error messages

The compilation of the instruction list and the testing of the program is simplified through the display of error messages.

## Syntax errors within a command line

These errors can occur during editing of a line or with read-in via the interface.

- 0 Invalid command
- 1 Operand for jump is not a label  
(this can only occur with read-in via the interface.  
With the jump command a specification of the operand type is available).
- 2 Invalid operand type  
(the command should not be combined with the operand)
- 4 Operand external to the permissible range  
(the number spec. is too high or odd address for word and doubleword)
- 5 No limiter after command  
(this can only occur with read-in via the interface. Remark after the command was not marked by  
"I" or "A".)
- 6 No end of line found  
(this can only occur with read-in via the interface. Remark too long)

## Program-related syntax errors

These errors are detected during the translation process. The editor indicates the line in which the error was detected. When the PLC-program is translated after power-on (for instance, after editing within the PLC-program and subsequent control switch-off), the error message PLC PROGRAM ERROR Nr. is displayed with flashing.

Remedy: Switch-off and on again and call-up PLC-editor via the code number. The editor indicates the place of error.

- 7 Called label undefined
- 8 No program end criterion found  
(within the program no BE or SP-instruction is to be found, behind which no LBL-instruction is located)
- 9 Program too long (RAM overflow)  
(The program code to be generated cannot be incorporated into the available store)
- 10 Assignment within a bracket  
(a =, S, SN, R, RN, PS-instruction was programmed although another calculation bracket had been opened)
- 11 Bracket nesting level too high  
(more than 16 nested brackets were opened)
- 12 Jump into a gating sequence  
(an unconditional jump was programmed although the gating sequence was not completed by an assignment)
- 13 Bracket closed without bracket open  
(a bracket close command was programmed although no bracket was opened)
- 14 Label within a bracket  
(a LBL-instruction was programmed even though a bracket was opened)
- 15 Label within a gating sequence  
(a LBL-instruction was programmed even though the previous gating sequence was not completed by an assignment)
- 16 Jump within a bracket  
(a jump instruction was programmed, although a bracket was opened)
- 17 Bracket opened at end of block  
(a BE-instruction was programmed, although a bracket was opened)
- 18 Label duplicated
- 19 Word assignment missing  
(a logic instruction was programmed, although the previous word-gating sequence was not completed by an assignment)



# Error messages

- 20 Logic assignment missing  
(a word assignment was programmed although the previous logic gating was not ended by an assignment)
- 21 Word accumulator not loaded  
(a word assignment or gating was programmed although the word accumulator contains no defined value)
- 22 Logic accumulator not loaded  
(a logic assignment was programmed although the logic accumulator contains no defined value)
- 23 Accumulators not loaded with bracket open  
(a A[, AN[, O[, ON[, XO[, XON[-command was programmed although neither word nor logic accumulator was gated further nor loaded)
- 24 Erroneous type bracket result  
(within the bracket another type was processed, i.e. logic instead of word or vice-versa, that which was originally intended with the open bracket command)
- 25 Conditional jump with invalid logic accumulator  
(a conditional jump was programmed, although the logic accumulator contains no defined value)

## Timing errors

These errors only occur during execution of the PLC program. The flashing error message PLC PROGRAM ERROR Nr. is displayed. After control switch-off and a new switch-on, the editor is obtained via the code number. The message ERRONEOUS ENTRY is then displayed. The editor is located either in the error line or – if the program cycle time has been exceeded – in the last jump instruction which was executed.

- 50 Nesting level too high  
(too many modules were nested)
- 51 Stack underflow  
(it was attempted to take data from the empty stack)
- 52 Stack overflow  
(it was attempted to load the stack with an illegal quantity of data)
- 53 Time out  
(the permissible program cycle time was exceeded by more than double. Check structure of subprograms)
- 54 Case out of range